



# Research Directions in Wind Turbine Blades: Materials and Fatigue

Presentation for

**GCEP - Stanford**

by

Paul Veers

Wind Energy Technology Department  
Sandia National Laboratories

Sandia is a multi-program laboratory operated by Sandia Corporation, a Lockheed Martin Company, for the United States Department of Energy under contract DE-AC04-94AL85000.



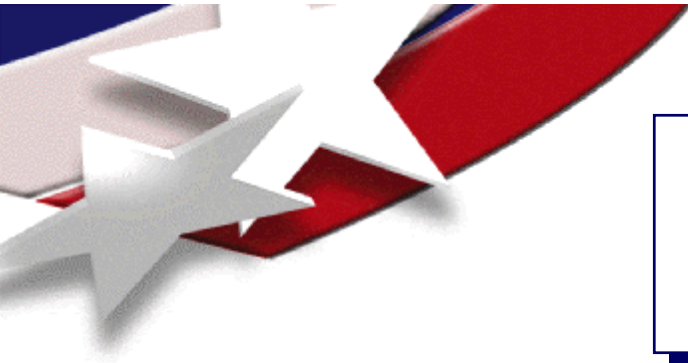

## Outline

- Context for blade research
- U.S DOE program blade activities
- What's going on now in research
  - Size and weight
  - Carbon fiber
  - Manufacturing
  - Design innovations
  - Load Mitigation
- Fatigue Issues
- Full Scale Testing
- Design Analysis
- Opportunities



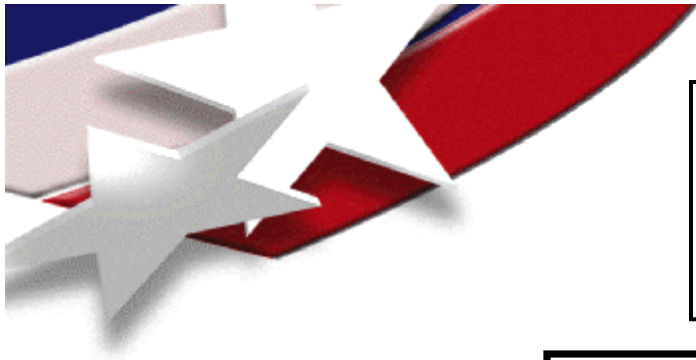

# Current Wind Industry Market

- Costs
  - System < \$3/lb
  - Blades < \$5/lb
  - ~ \$0.75/Watt
  - \$0.03-0.05/kWh

- Size
  - 1.5-5.0 MW
  - Towers: 65-100 m
  - Blades: 34-50m
  - Weight: 150-500t



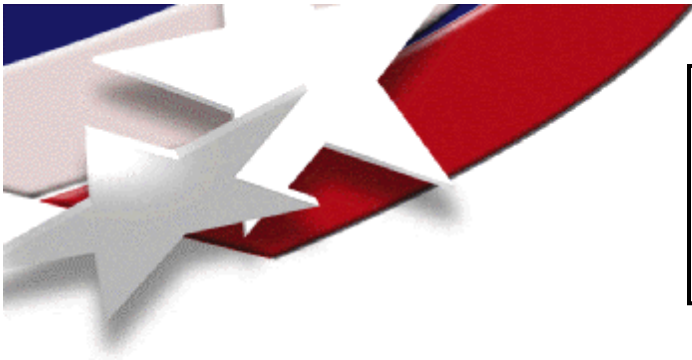

# DOE Wind Energy Program

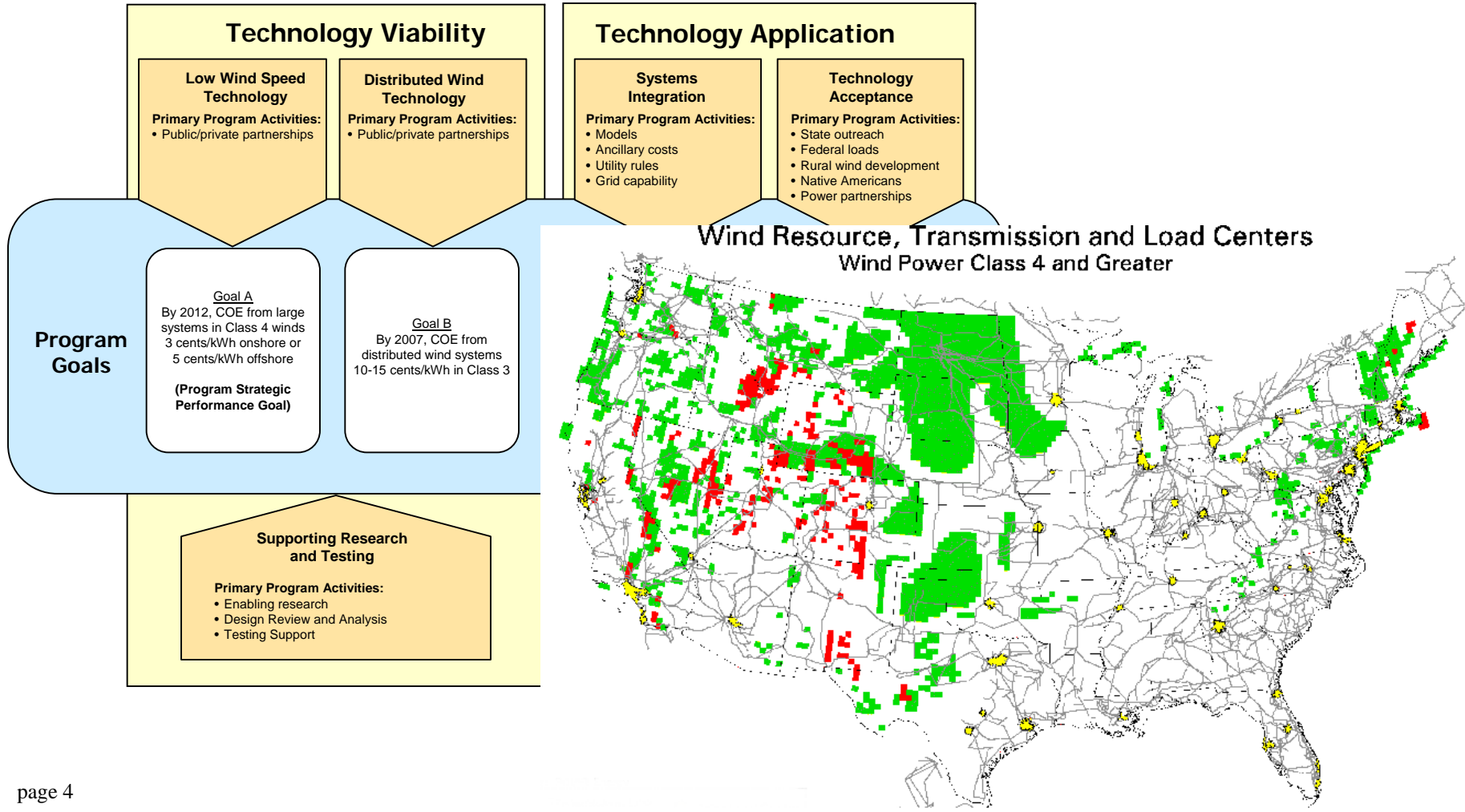

# Impact of Cost Goals

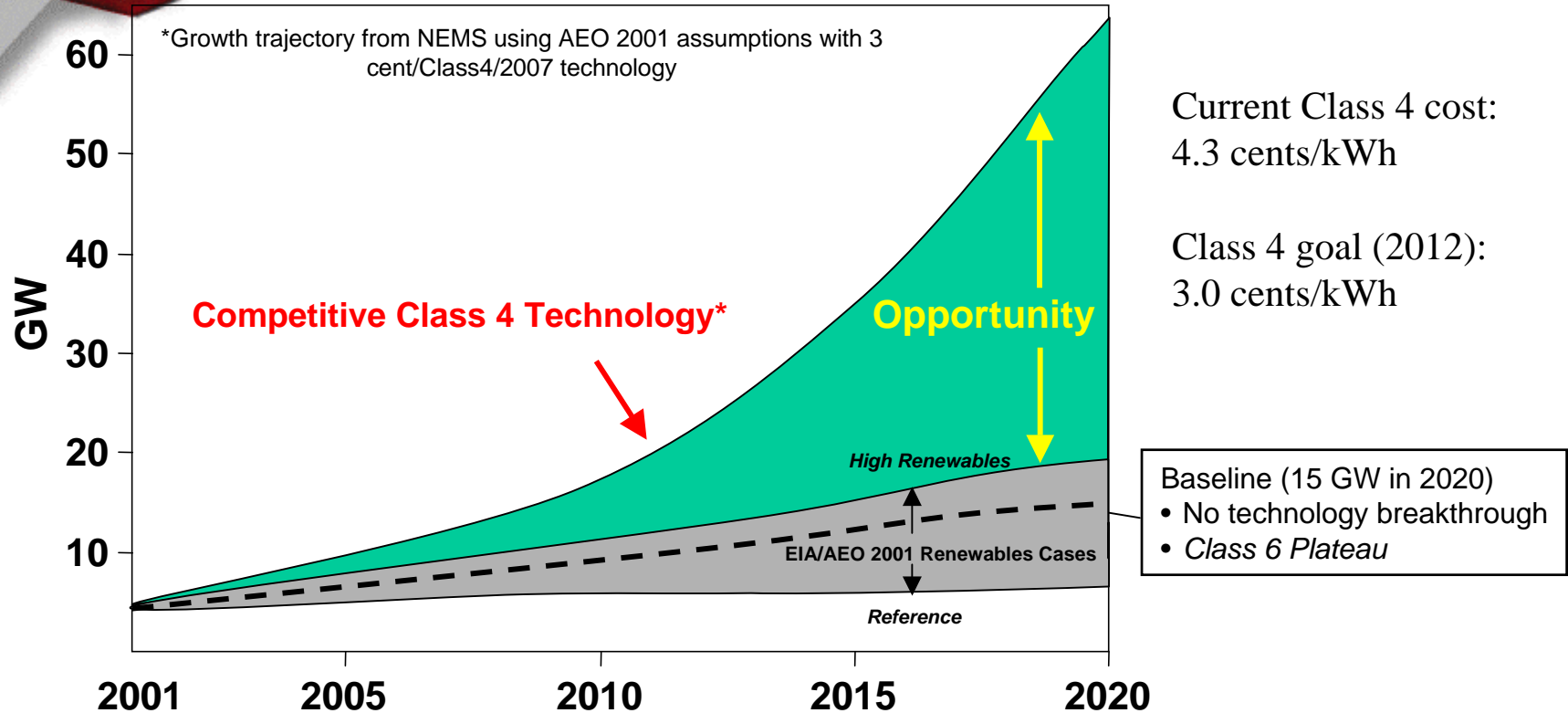

**Program Goal:**  
3 cents/kWh  
Class 4 COE  
in 2012

- Expands resource base **20-fold**
- Reduces average distance to load **5-fold**
- **35 GW** additional opportunity by 2020



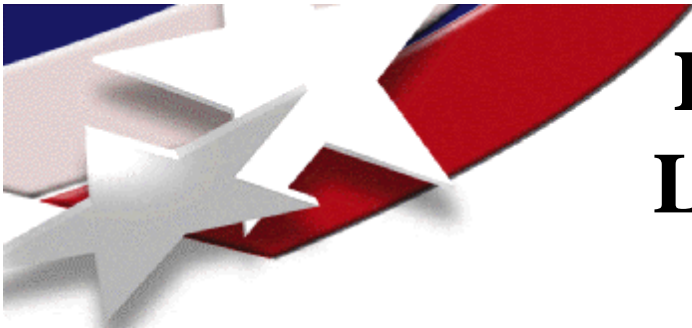

# How Do We Get to Low-Cost, Low-Wind-Speed Technology?

(Thresher: 5/02)

## Technology Improvements

## Estimated COE Improvement

- **Larger-scale 2 - 5MW** - (rotors up to 120m) 0% ± 5%
  - **Advanced rotors and controls** – (flexible, low-solidity, higher speed, hybrid carbon-glass and advanced and innovative designs) -15% ± 7%
  - **Advanced drive train concepts** - (Hybrid drive trains with low-speed PM generators and other innovative designs including reduced cost PE) -10% ± 7%
  - **New tower concepts** - (taller, modular, field assembled, load feedback control) -2% ± 5%
  - **Improved availability and reduced losses** - (better controls, siting and improved availability) -5% ± 3%
  - **Manufacturing improvements** - (new manufacturing methods, volume production and learning effects) -7% ± 3%
  - **Region and site tailored designs** (tailoring of larger 100MW wind farm turbine designs to unique sites) -5% ± 2%
- 44% ± 32%

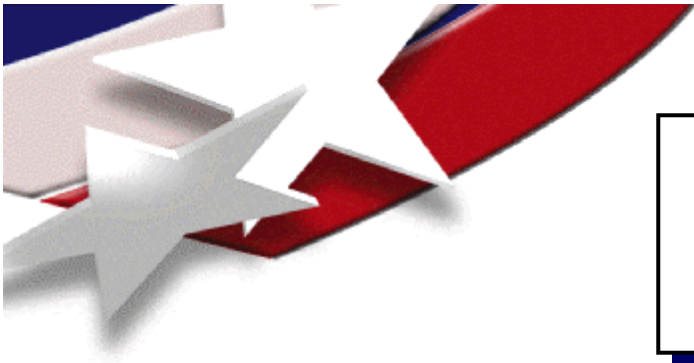

## Sandia Blade Workshop February 2004

- Blades are source of all energy and loads
- Typically 10-15% of system cost
- Even a small system improvement offsets a large increase in blade cost
- Perhaps we should be thinking of more expensive blades instead of lowering blade cost!



**The high payoff game:  
Larger rotor with the same loads**





# Wind Program Blade Research:

A Sandia–NREL partnership

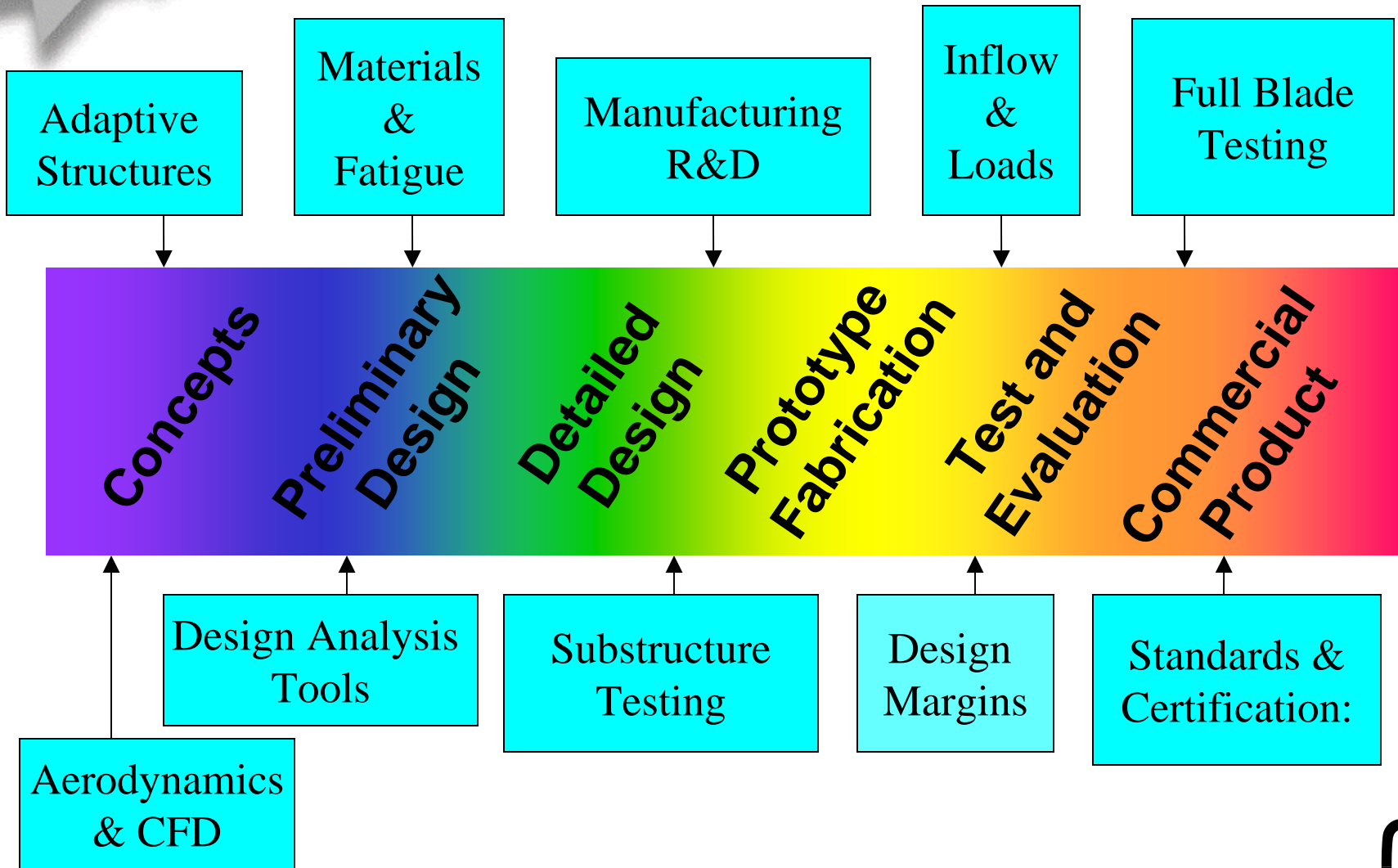

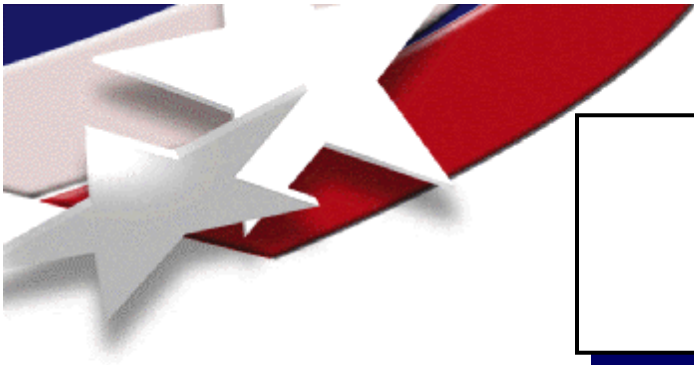

## Sandia Wind Energy Research Primary Responsibility – Blades

### Sandia Research Elements

- Advanced Blade Control – both active and passive (adaptive blade)
- Materials
- Manufacturing
- Analysis Tools
- Validation Testing & NDI
- Field Testing and Instrumentation
- Reliability

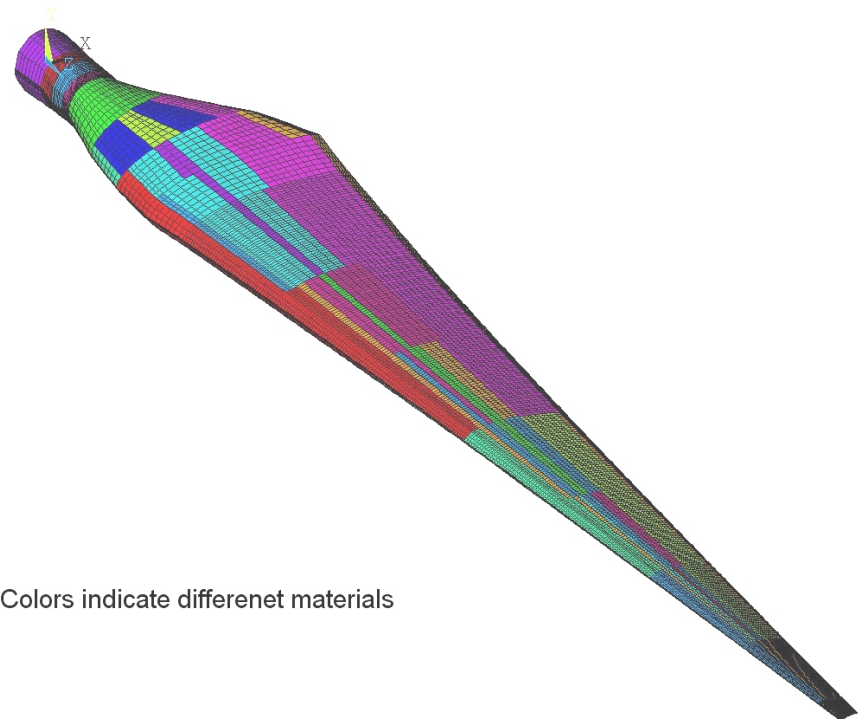

Colors indicate different materials

➤ **Sandia has the core competency in solid mechanics**



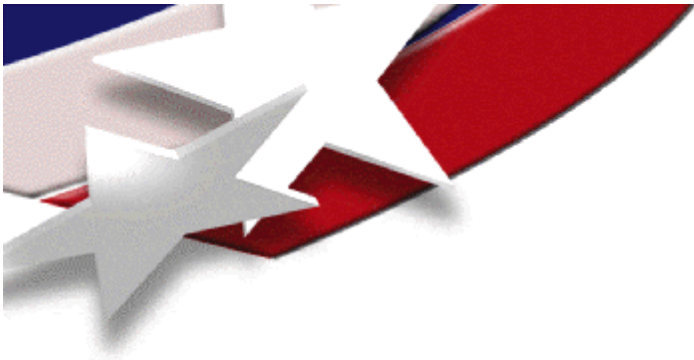

## Design Evaluation Relies Heavily on Testing at NREL



Fatigue Test on  
a 34 meter  
blade test at  
NREL/NWTC





# Blade Size over Time

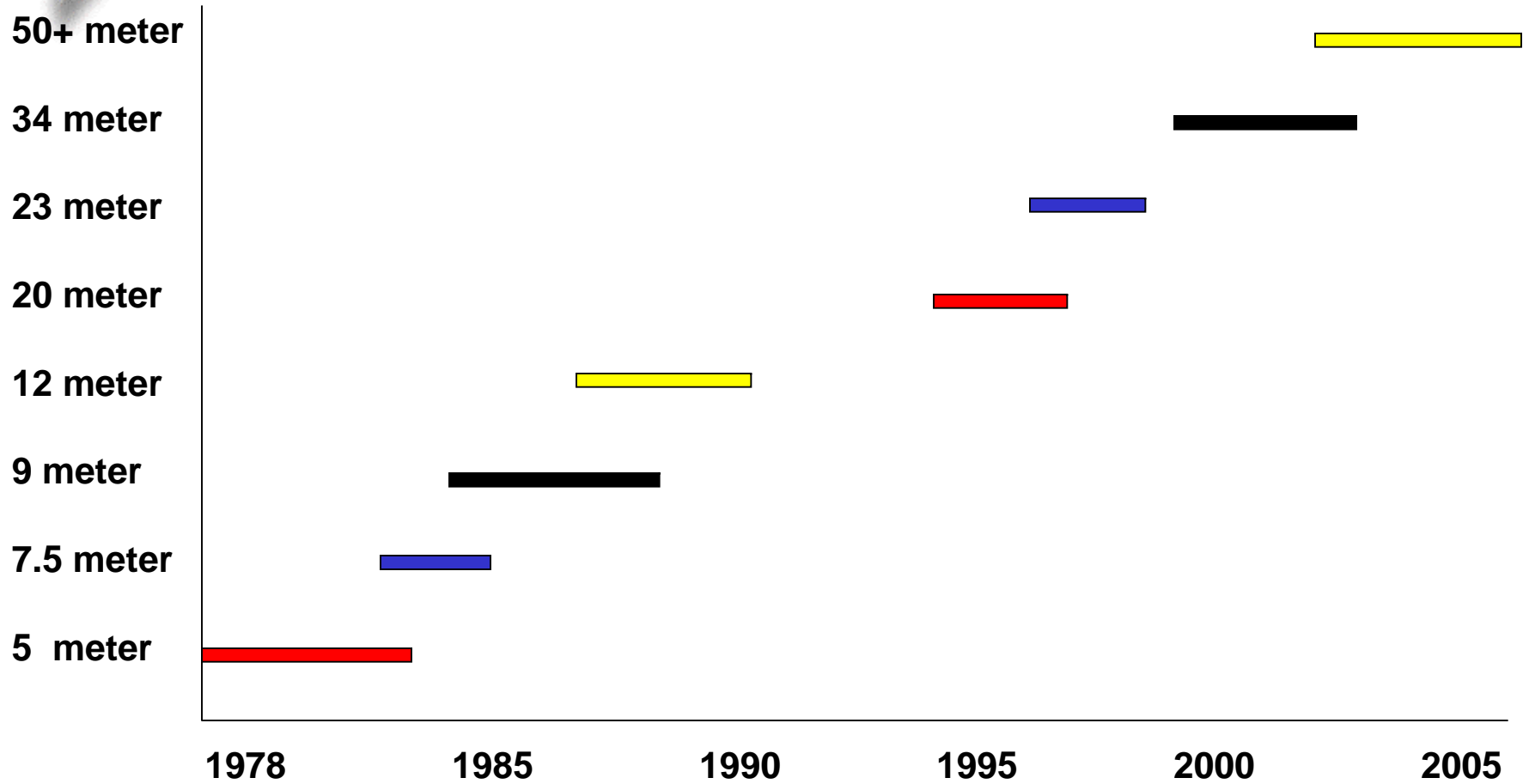



50.5 Meter Blade  
(GE 3.6 MW turbine)



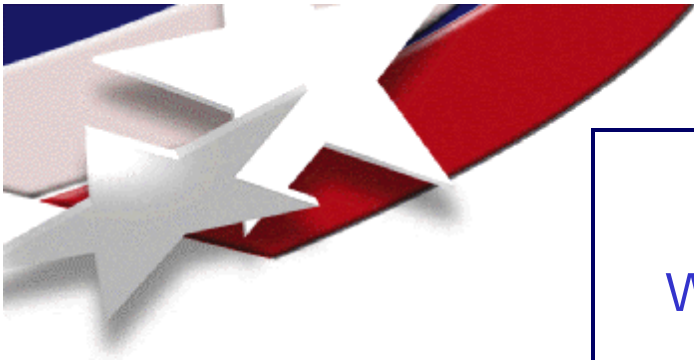

## Comparison of Weight Trends WindStats Data & New Design Concepts

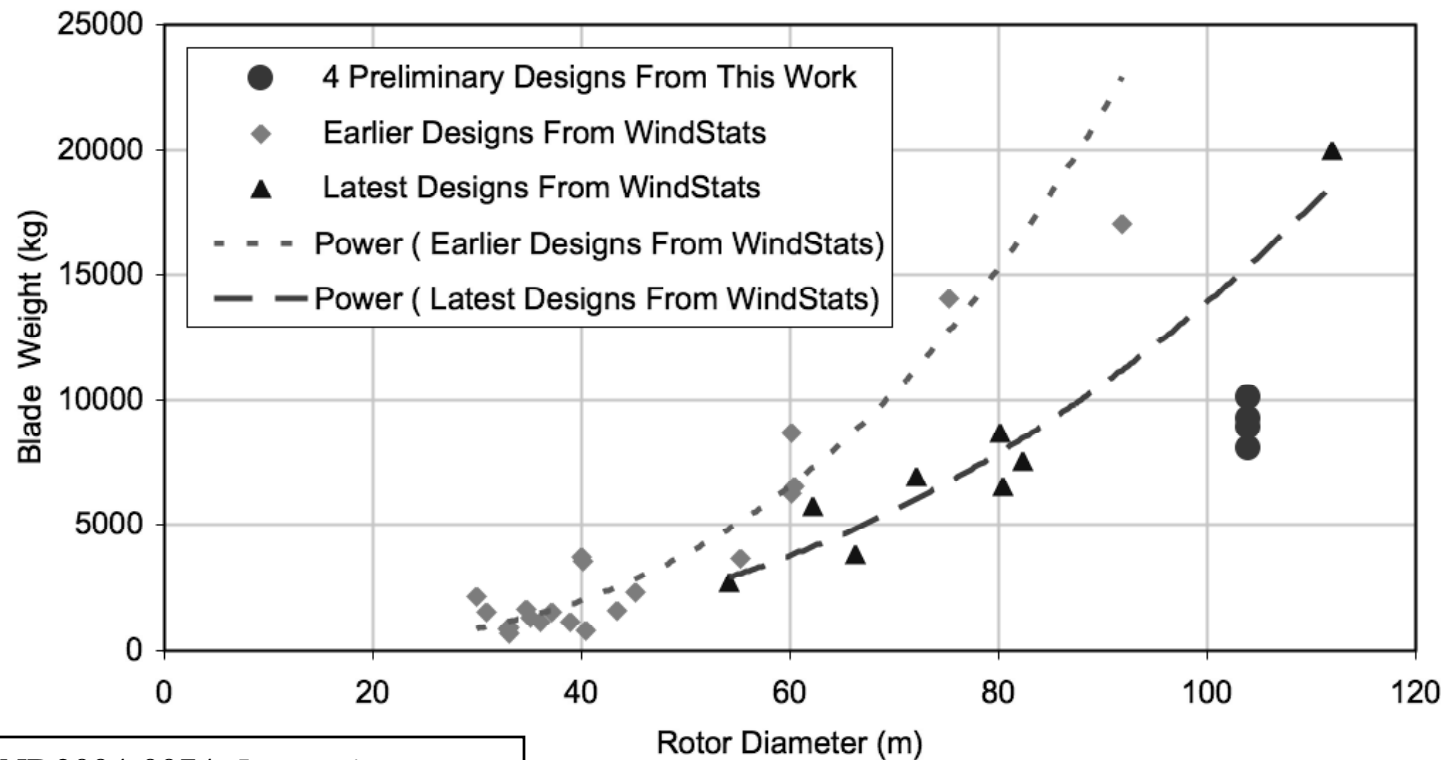

SAND2004-0074, *Innovative Design Approaches for Large Wind Turbine Blades; Final Report, TPI*



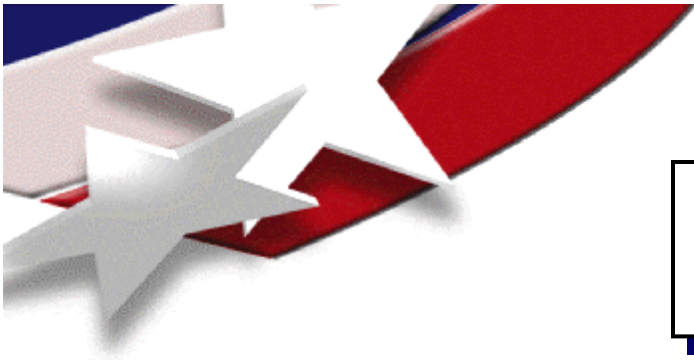

# Classic Blade Design

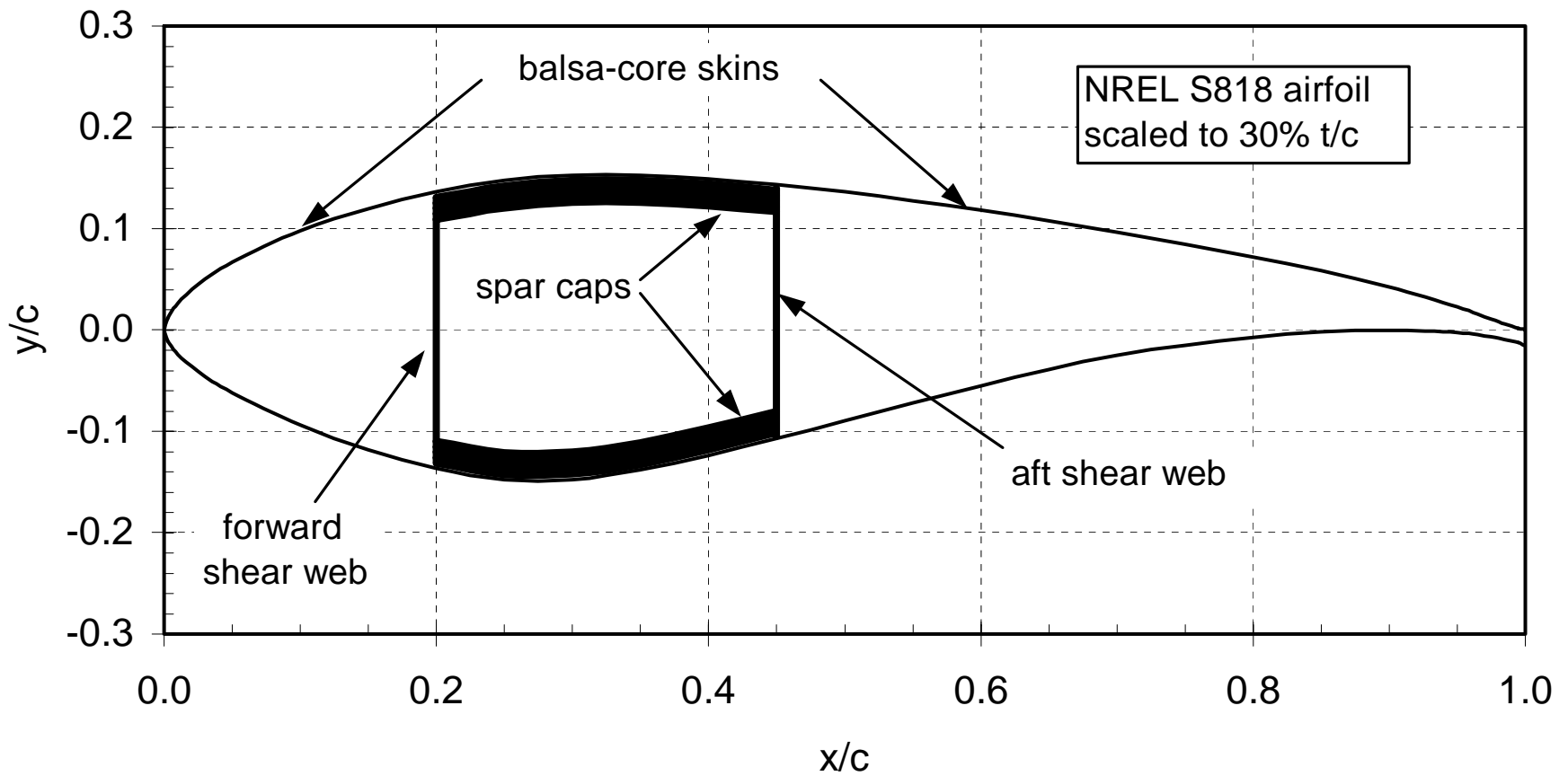

# New Materials: New Issues

- Carbon fiber forms
  - Cost vs. Performance
  - Tow Size
  - Pre-preg vs. fabrics
- Manufacturing process
- Fiber straightness
- Carbon/Glass hybrids
- Carbon-to-Glass Transitions
- Resin systems

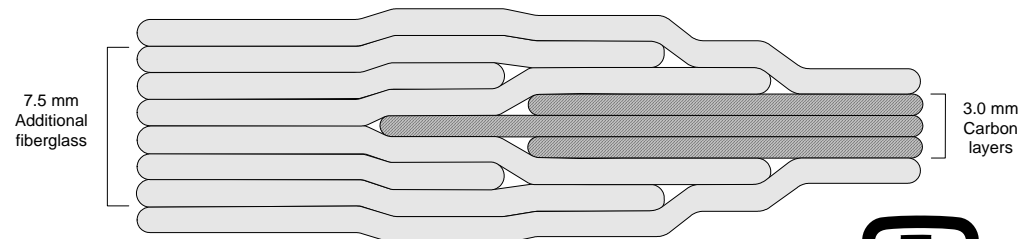
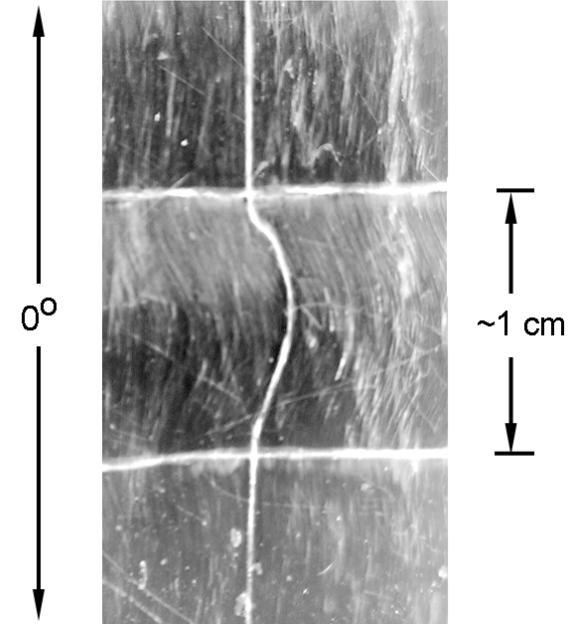
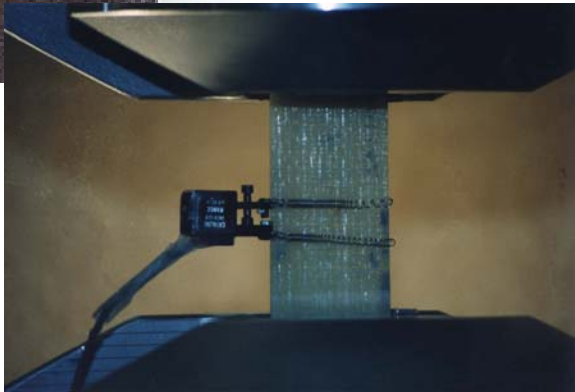

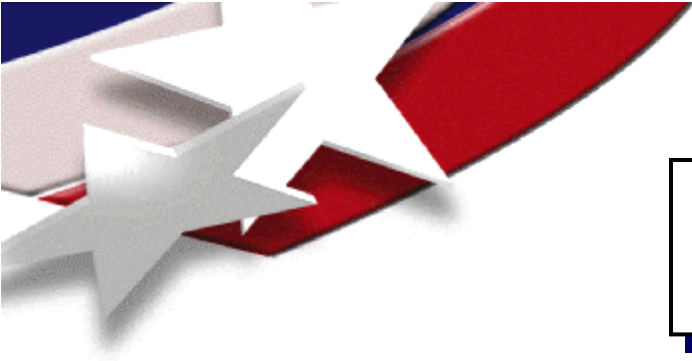

## Carbon Fiber has it's Problems

- Competition with high quality fibers
- Availability of precursors
- Large investment for increment in fiber production capacity
- Difficult infusion – may require new manufacturing process
- Straightness requirement
- Low strain limit in compression
- Variability of fatigue properties in compression
- Cost

**Vestas release of the V-90 suggests problems are manageable.**



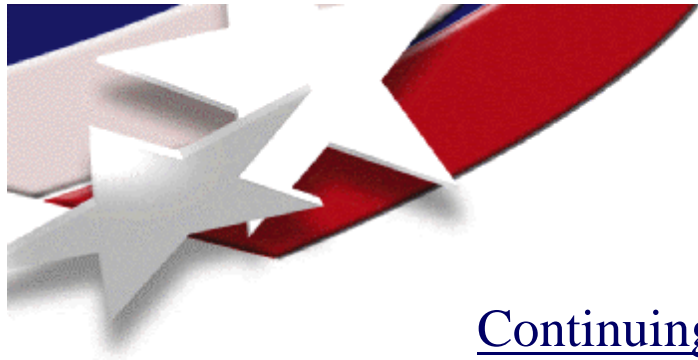

## Partners in Blade Manufacturing

### Continuing

- GEC carbon fiber studies
- TPI Composites
  - TPI and Mitsubishi have a joint venture – Vientek in Juarez, Mexico
  - Manufacturing 34-39 meter blades
  - Partnership with GEC

### New

- GE Global Research
- Knight and Carver
  - Los Angeles Yacht Builders
- HITCO Carbon Composites
  - Gardena, CA Co.

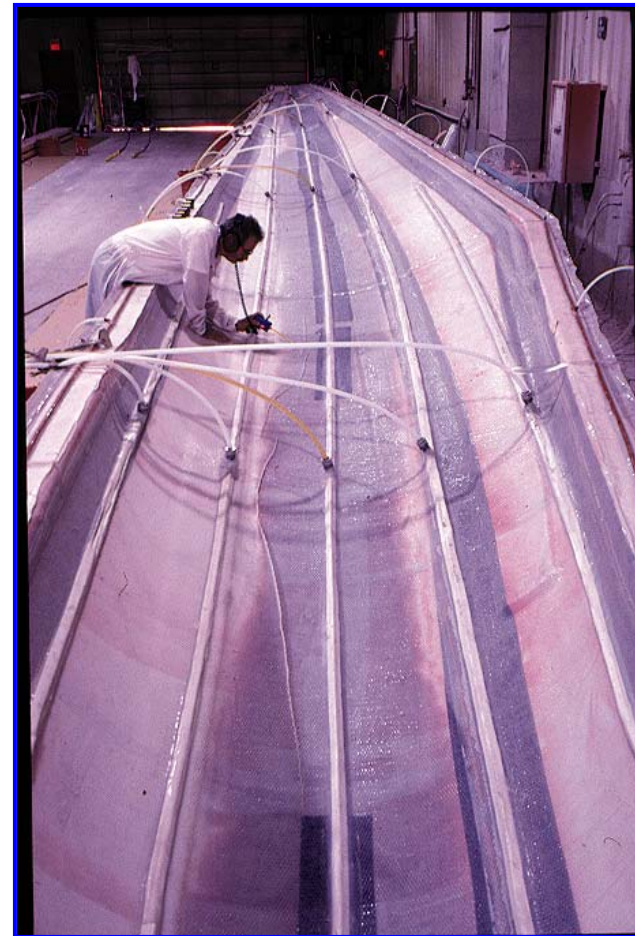

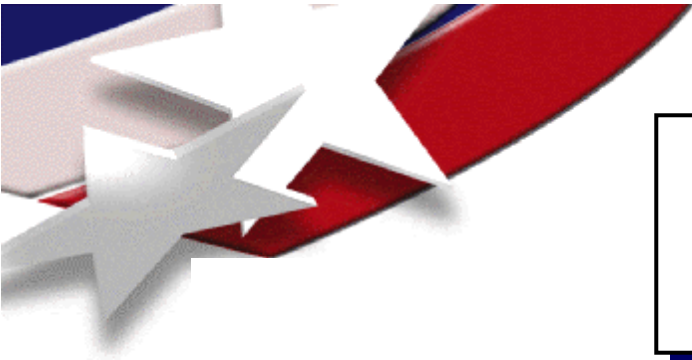

## Design Studies identify the inner-span for thicker airfoils

- A thicker airfoil opens up new manufacturing opportunities
  - Constant thickness spar cap
  - Pre-manufactured spars (e.g., Pultrusion)
- Weights are reduced substantially without other (material) changes

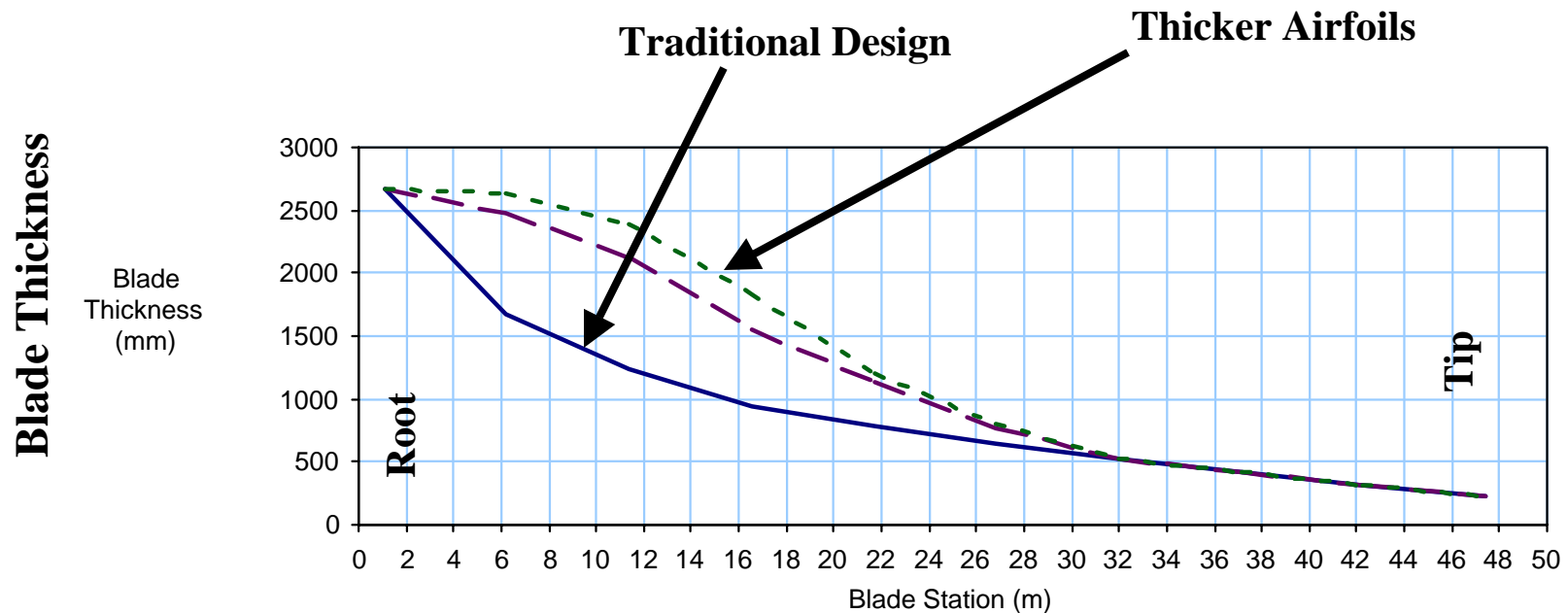

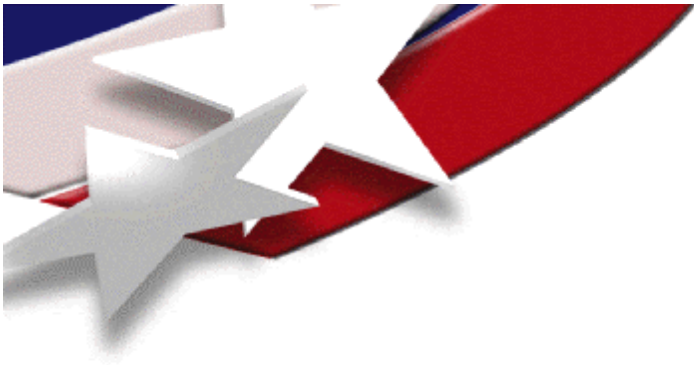

# Examples of Flatback Airfoils

**FB-6500-2000 at 15% Radius**

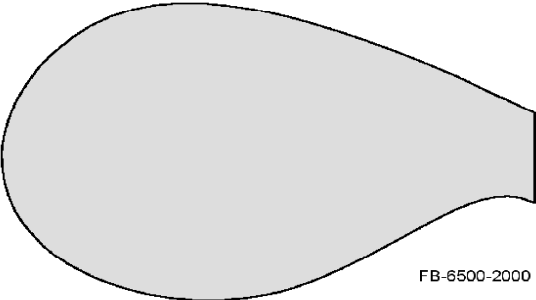

**FB-4300-0860 at 35% Radius**

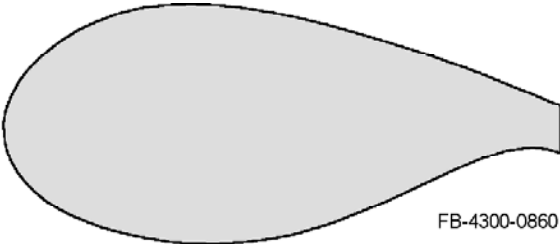

**FB-5100-1100 at 25% Radius**

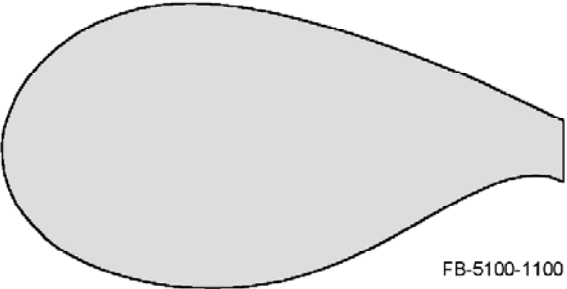

**FB-3500-0560 at 45% Radius**

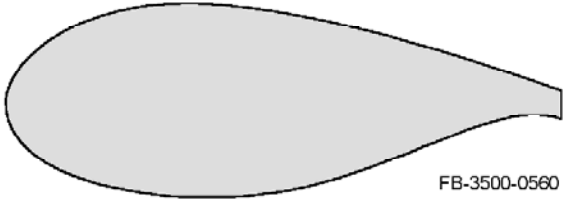



# Adaptive Blades Load Mitigation

## Passive Bend-Twist Coupling

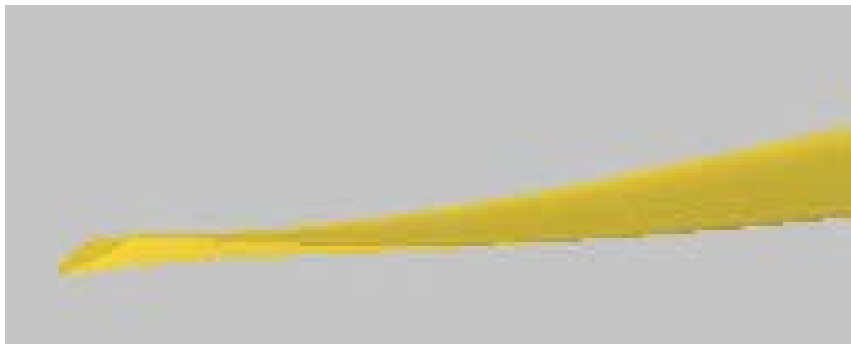
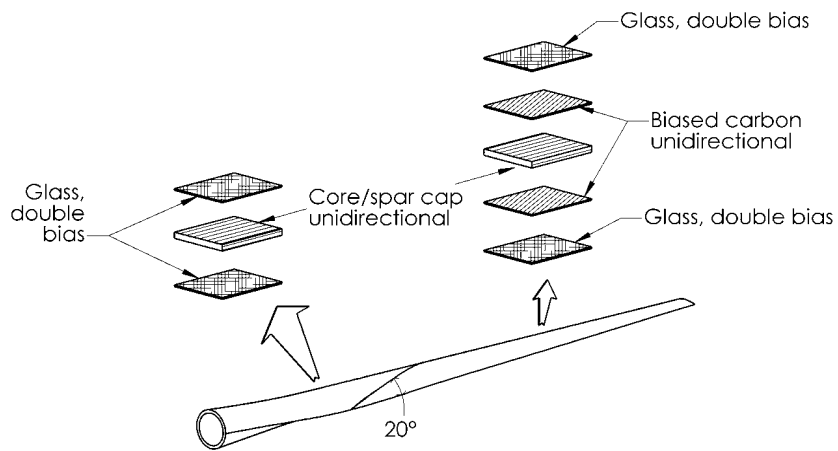

## Active Micro-tab Assembly & Motion

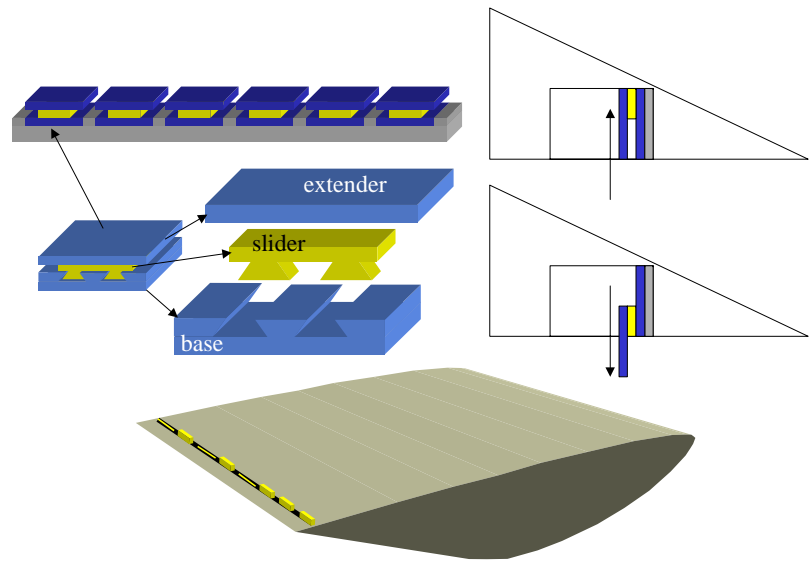

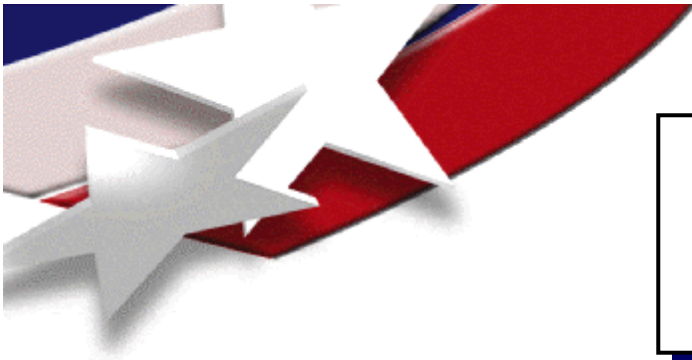

# Issues in Fatigue

Fatigue driven failure of the major structural components has not been a large contributor to system failure. **However, it drives system cost.**

**Component Failures Reported in Denmark  
4th Quarter 2001**

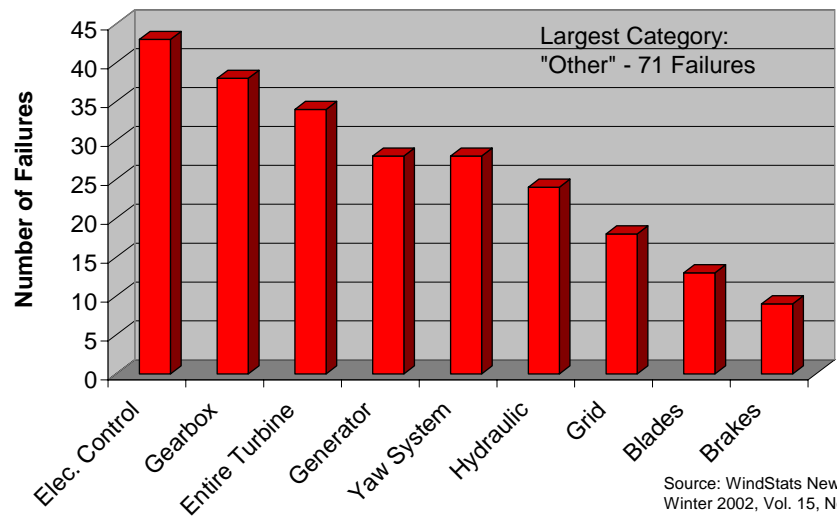

Source: WindStats Newsletter  
Winter 2002, Vol. 15, No. 1.



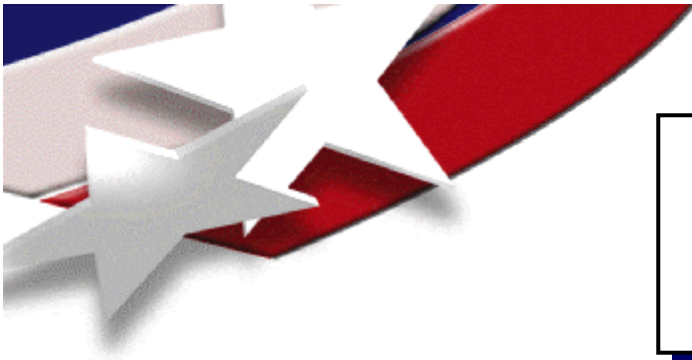

## Issues in Fatigue (continued)

- **Material Properties**
  - Composites Industry – divided between aerospace and consumer products
  - Coupon vs. full scale
  - Material Variability
- **Load Spectra**
  - Designs are qualified using aeroelastic simulation results
  - Simulation uses assumed (and standard) site conditions
  - Aeroelastic models are verified with field test data
  - Relationship to site characteristics
  - Site Variability
- **Damage Models**
  - Miner's Rule vs. non-linear damage models
  - Fracture Mechanics
  - Residual Strength
  - Sequence Effects
- **Design Margins**
  - Safety Factors defined in international standards
  - Coupon and component testing to reduce margins
  - Site-specific design loads to replace “one size fits all” margins
  - Shifting design drivers in low wind speed sites
  - Standardization vs. Optimization



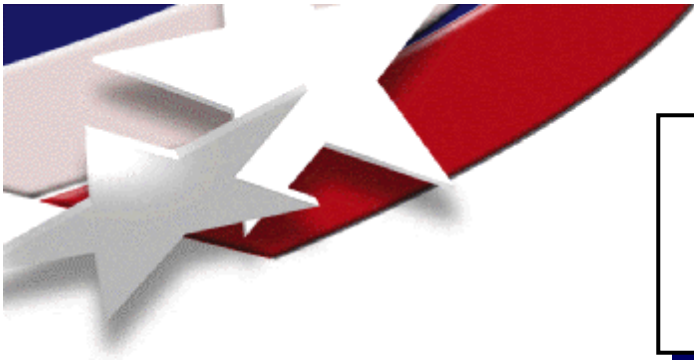

## Fatigue Testing at Risø Roskilde, Denmark

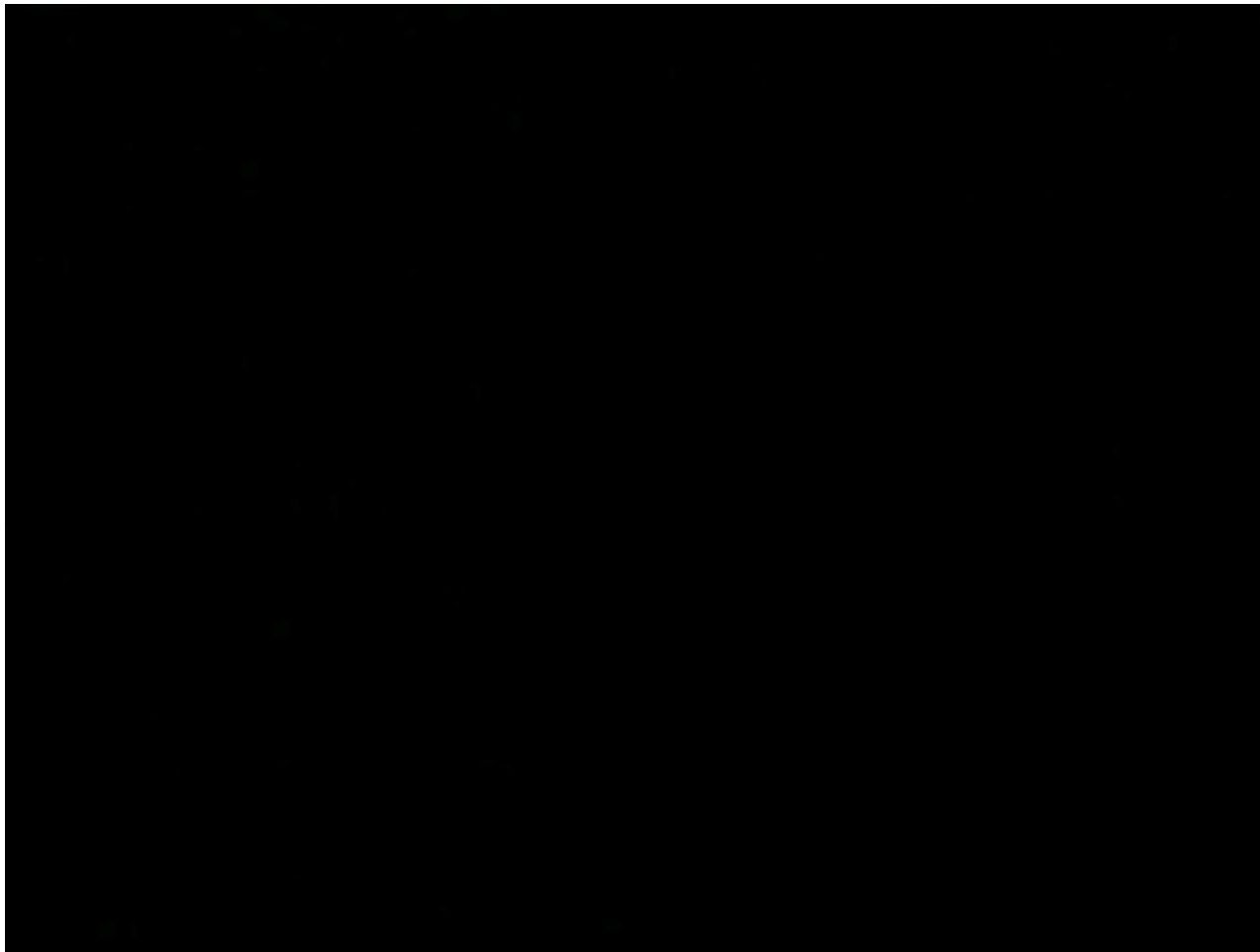

Every blade  
design /  
manufacturing  
combination  
must be verified  
by full scale  
testing.



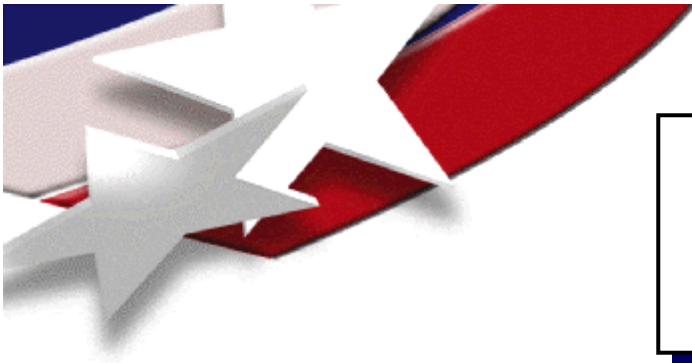

## Blade Testing at the Netherlands (ECN) “Knowledge Center”



**Full Scale blade testing  
at  
Knowledge Centre  
WMC**

Fatigue failures initiate at local weak spots and evolve into loss of stiffness

Ultimate load failure is usually buckling, but point of initiation is sometimes difficult to determine.



# Design Tools: Validation and Testing

Design, analyze, fabricate,  
and test composite material  
structures to develop new  
approaches to design and  
analysis of blades

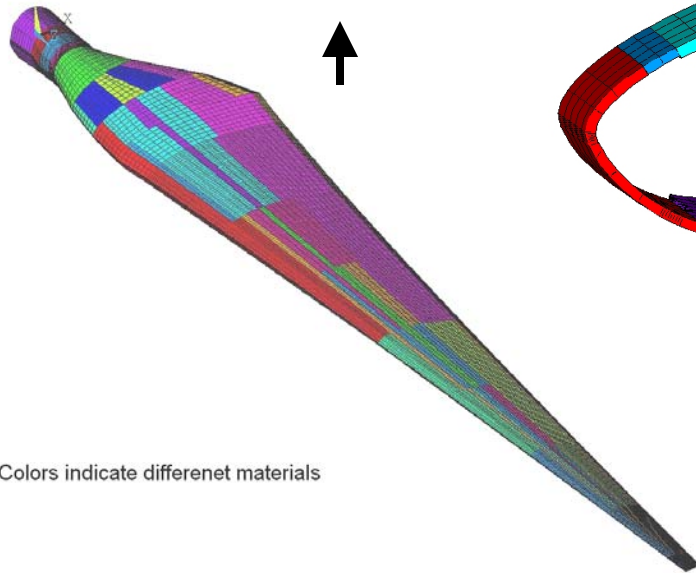

Colors indicate different materials

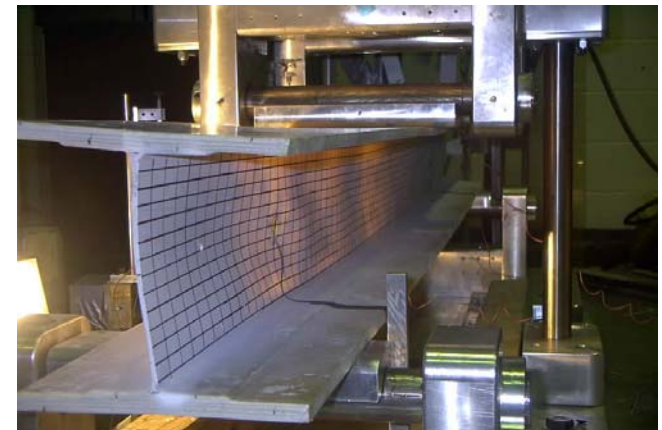
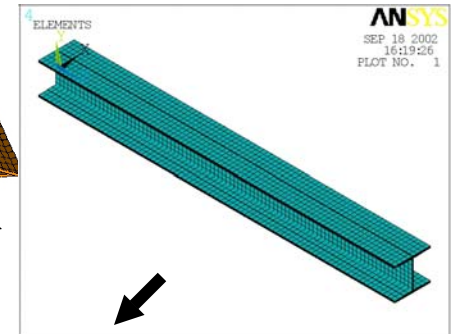
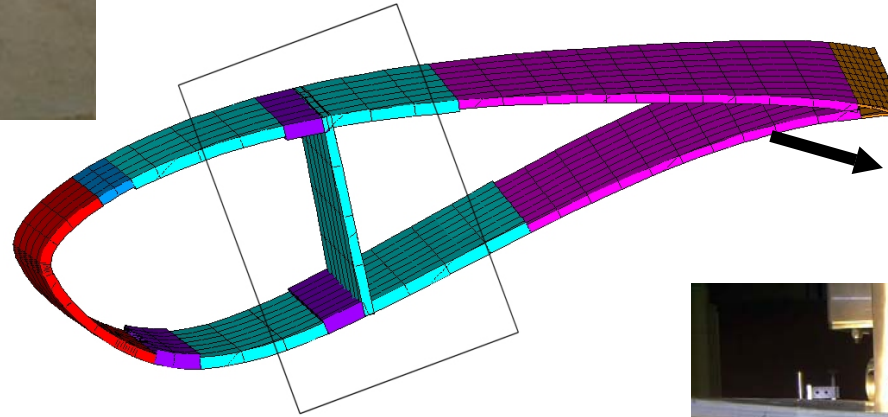

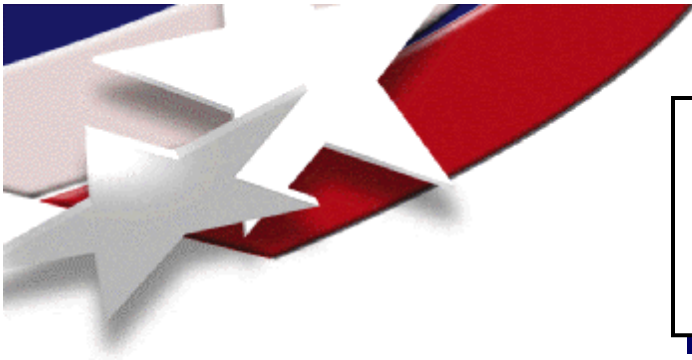

## Innovation Opportunities

- Load alleviation
- Lighter and stiffer designs
- Anticipatory control
- Embedded control activation
- Aeroelastic tailoring
- Improved manufacturing of joints and bond lines
- Analysis capability that is predictive of failure mode
- Improved panel buckling restraint and novel internal structure
- Thicker inboard airfoils
- Tip noise reduction
- Spanning the gap between composites for aerospace and boat hulls
- Embedded condition monitoring – system reliability enhancement
- ...



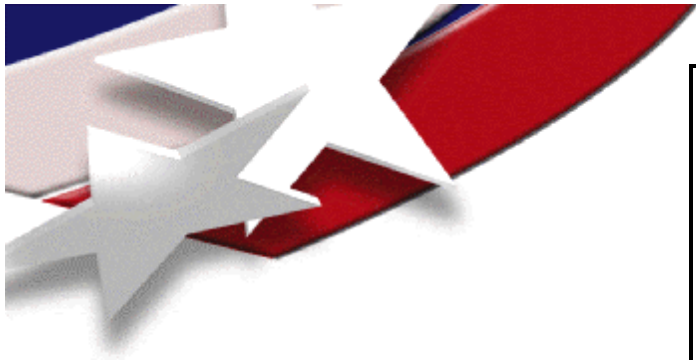

# Blades: Issues & Opportunities

Questions?



Horn's Reef,  
Denmark

