

*In Pursuit of a H<sub>2</sub> Economy for  
Mitigating Climate Change...*

*How Important is  
Advancing the State-of-the-Art in  
H<sub>2</sub> Production from Fossil Fuels?*

Tom Kreutz

*Princeton Environmental Institute  
Princeton University*

*Presented at the GCEP Energy Workshop:  
“Carbon-Free Production of Hydrogen”  
April 26, 2004, Stanford University, Palo Alto, California*

# *Outline of Talk*

- Overview of our work on production of carbon-free H<sub>2</sub> and electricity from fossil fuels (primarily coal)
- Putting our work in perspective
- Areas of interest for future work

# *The Carbon Mitigation Initiative (CMI) at Princeton University, 2001-2010*

- CMI Project Areas:
  - *Carbon capture (Kreutz, Larson, Ogden, Socolow, Williams)*
  - *Carbon storage (Celia)*
  - *Carbon science (Pacala, Sarmiento, GFDL)*
  - *Carbon policy (Bradford, Oppenheimer)*
  - *Integration (Socolow, Pacala)*
- Funding: 15.1\$ from BP, 5 M\$ from Ford

# World Consumption of Primary Energy

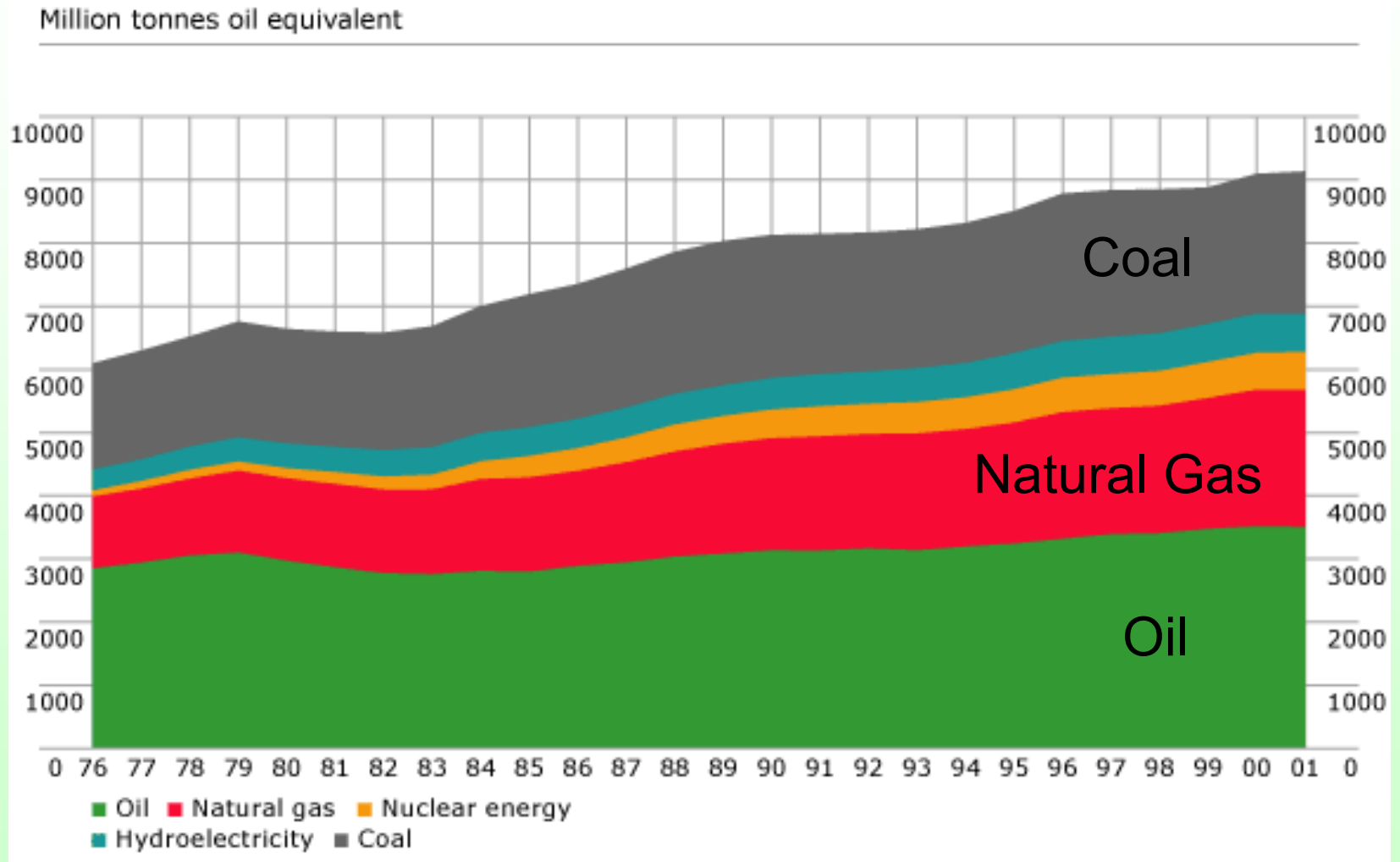

From: <http://www.bp.com/centres/energy2002/primary.asp#>

# *Motivation for Studying Coal (vs. Gas)*

- *Plentiful.* Resource ~ 500 years (vs. gas/oil: ~100 years).
- *Inexpensive (low volatility).* 1-1.5 \$/GJ HHV (vs. gas at 2.5+ \$/GJ).
- *Ubiquitous.* Wide geographic distribution (vs. middle east).
- *Carbon intensive.*
- *Potentially clean.* Gasification, esp. with CCS, produces few gaseous emissions and a chemically stable, vitreous ash.
- *Ripe for innovation.*
- *Globally significant.* For example: China: extensive coal resources; little oil and gas. Potential for huge emissions of both criteria pollutants and greenhouse gases.

# *Our Work on Low-CO<sub>2</sub> Hydrogen and Electricity from Fossil Fuels*

- Coal (entrained flow gasification at 70 bar):
  - H<sub>2</sub> / CO<sub>2</sub> separation with WGS membrane reactors,
  - Conventional H<sub>2</sub> and CO<sub>2</sub> separation:
    - Electricity-only (IGCC) plants
    - H<sub>2</sub> + electricity plants
- Natural gas:
  - SMR and ATR with steam and combined cycles

# Generic Process: Coal to H<sub>2</sub>, Electricity, and CO<sub>2</sub>

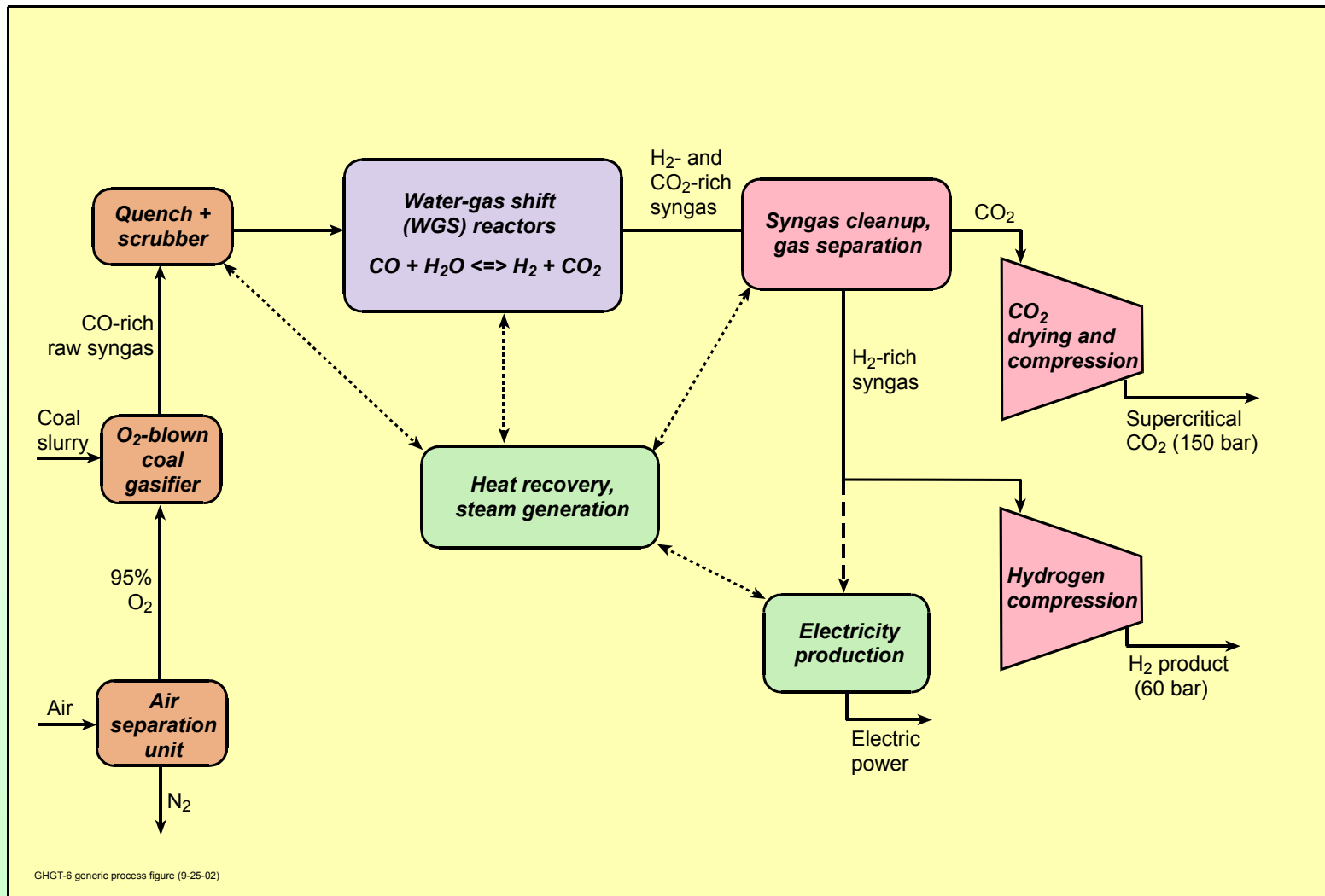

- All work presented here is based on O<sub>2</sub>-blown, entrained flow, coal gasification (e.g. Texaco, E-Gas gasifiers).

# *Process Modeling*

- Heat and mass balances (around each system component) calculated using:
  - Aspen Plus (commercial software), and
  - GS (“Gas-Steam”, Politecnico di Milano)
- Membrane reactor performance calculated via custom Fortran code
- Component capital cost estimates taken from the literature, esp. EPRI reports on IGCC
- Benchmarking/calibration:
  - Economics of IGCC with carbon capture studied by numerous groups
  - Used as a point of reference for performance and economics of our system
  - Many capital-intensive components are common between IGCC electricity and H<sub>2</sub> production systems (both conventional and membrane-based)

# Estimates of Overnight Component Capital Costs

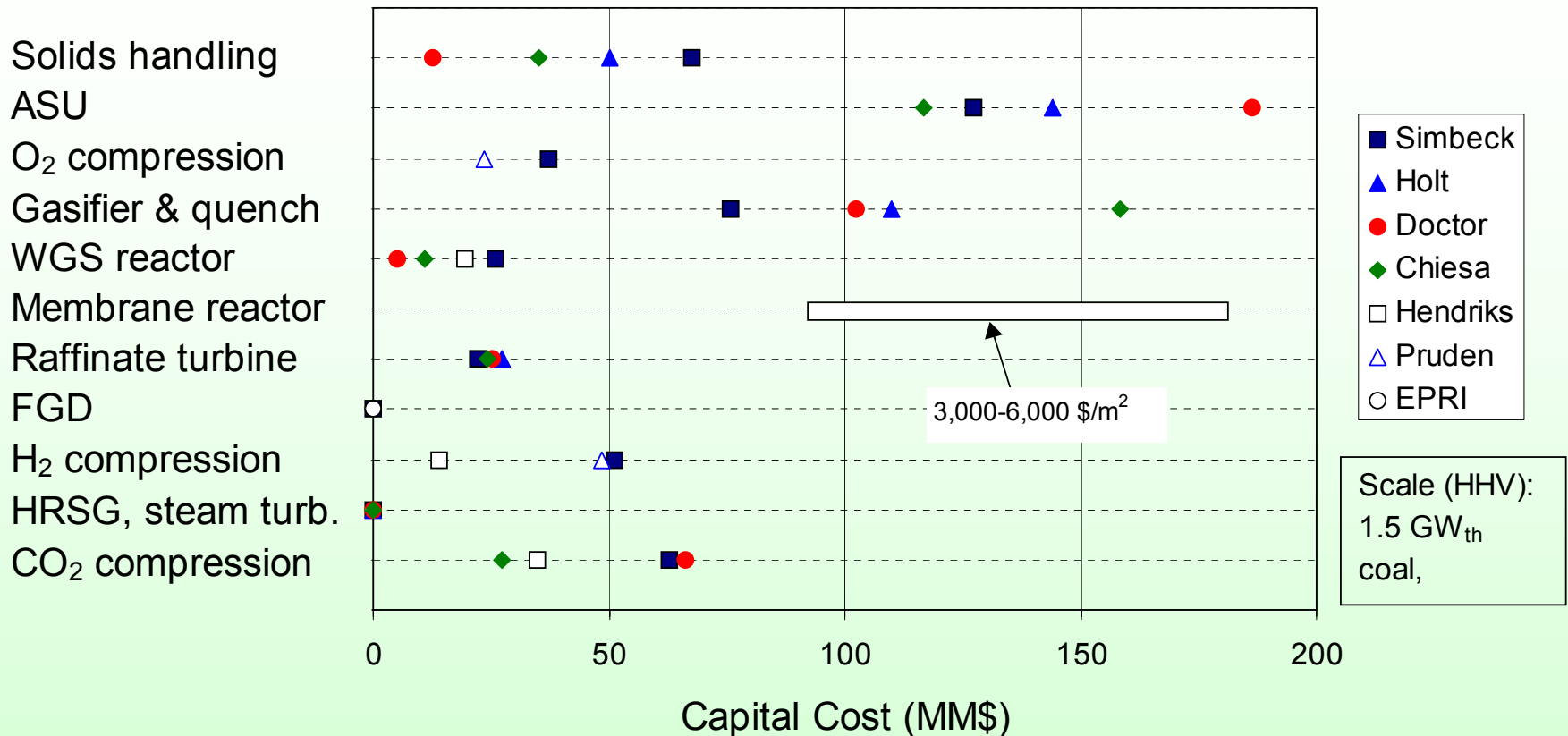

- Significant variation found in cost values, methodology, and depth of detail.
- Our cost model is a self-consistent set of values from the literature.
- Cost database is evolving; less reliable values removed; range is narrowing.
- Uncertainty shown above leads to an uncertainty of  $\pm 10-15\%$  in H<sub>2</sub> cost.

# *Economic Assumptions*

Coal price (2001 average cost to electric generators)	1.2 \$/GJ (HHV)
Capacity factor	80%
Capital charge rate	15% per yr
Interest during construction	12.0% of overnight capital
O&M costs	4% of overnight capital per year
CO <sub>2</sub> transport + storage cost*	5 \$/mt CO <sub>2</sub> (~8.6 ¢/kg H <sub>2</sub> )
U.S. dollars valued in year	2002
Plant scale	~ 1 GW <sub>th</sub> H <sub>2</sub> (LHV)
Coal Type	Illinois #6

- “Best case” cost estimate for: 16,000 tonne/day CO<sub>2</sub>, 100 km pipeline, 2 km deep injection well (layer thickness > 50 m, permeability > 40 mDa)

# Sensitivity of Cost to CO<sub>2</sub> Storage Costs

Order of magnitude increase in CO<sub>2</sub> storage costs increases electricity and H<sub>2</sub> costs by 60-70%.

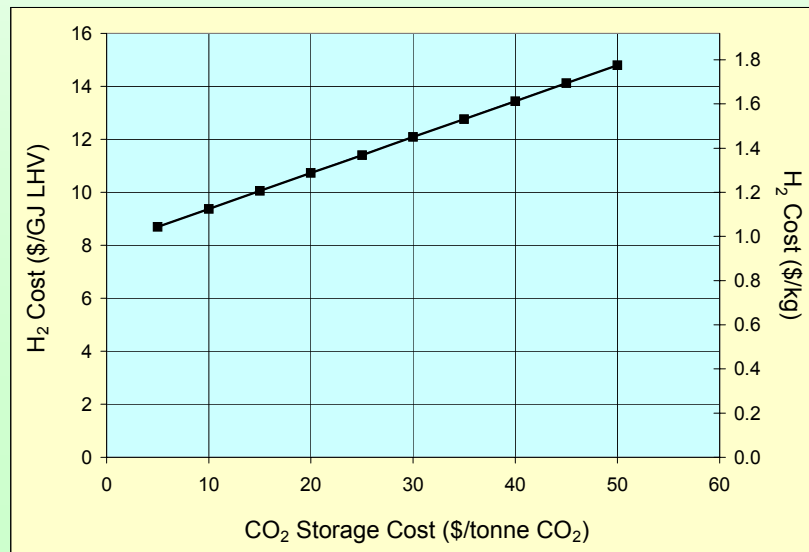
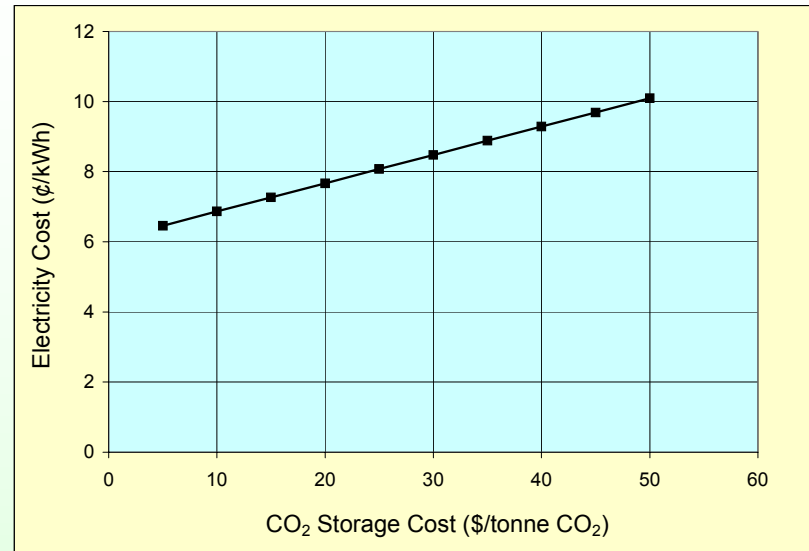

# Disaggregated Cost of H<sub>2</sub> Production

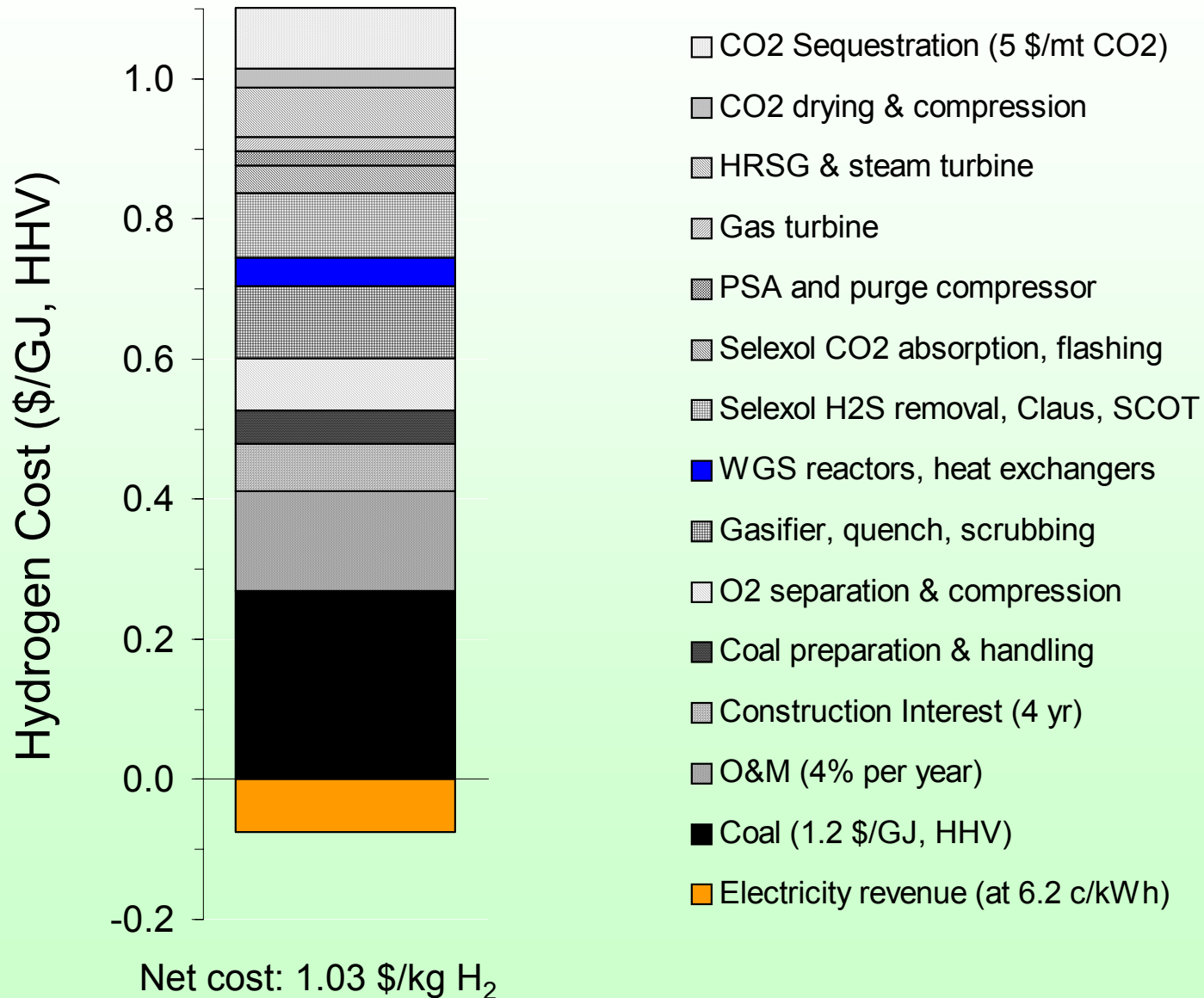

# *A Few Conversion Factors*

- Thermal energy (LHV):

1 kg H<sub>2</sub> ~ 1 gallon gasoline

(so \$/kg H<sub>2</sub> = \$/gallon gasoline)

- 1 \$/kg H<sub>2</sub> = 7.05 \$/GJ HHV = 8.34 \$/GJ LHV

# *System Parameter Variations*

## *System Performance:*

- gasifier/system pressure
- syngas cooling via quench vs. syngas coolers
- hydrogen recovery factor (HRF)
- hydrogen purity
- sulfur capture vs. sulfur + CO<sub>2</sub> co-sequestration
- membrane reactor configuration
- membrane reactor operating temperature
- hydrogen backpressure
- raffinate turbine technology (blade cooling vs. uncooled)

## *System Economics (Sensitivity Analysis):*

- membrane reactor cost (and type)
- co-product electricity value, capacity factor, capital charge rate, fuel cost, CO<sub>2</sub> storage cost, etc.

# Annual U.S. Carbon Emissions (2000)

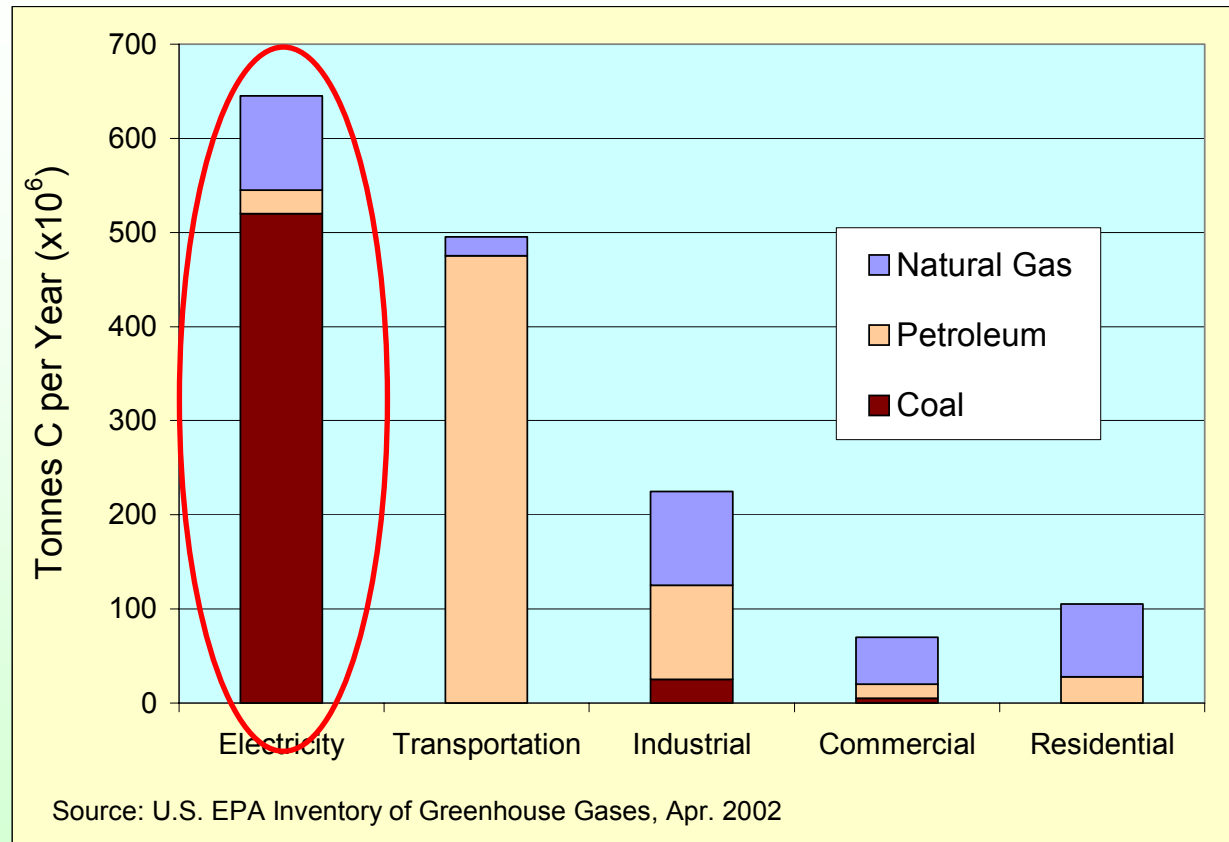

- Let's focus for a moment on the power market...

# “Commercially Ready” Coal IGCC with CO<sub>2</sub> Capture

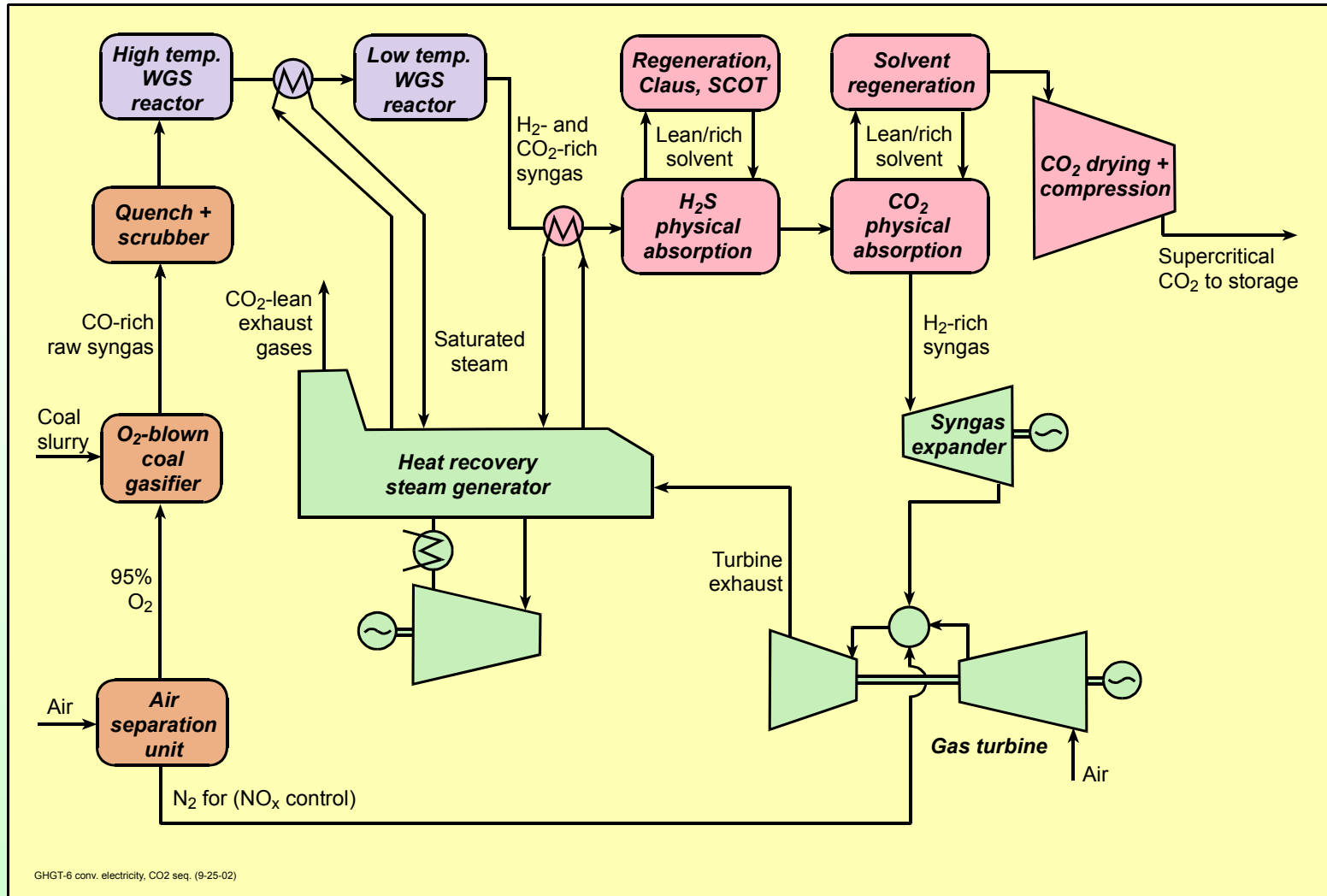

- CO<sub>2</sub> venting: 390 MW<sub>e</sub> @ \$1190/kW<sub>e</sub>,  $\eta^{LHV} = 43.0\%$ , 4.6 ¢/kWh
- CCS: 362 MW<sub>e</sub> @ \$1530/kW<sub>e</sub>,  $\eta^{LHV} = 36.8\%$ , 6.2 ¢/kWh (no carbon tax)

# Economics of Coal IGCC with Carbon Storage

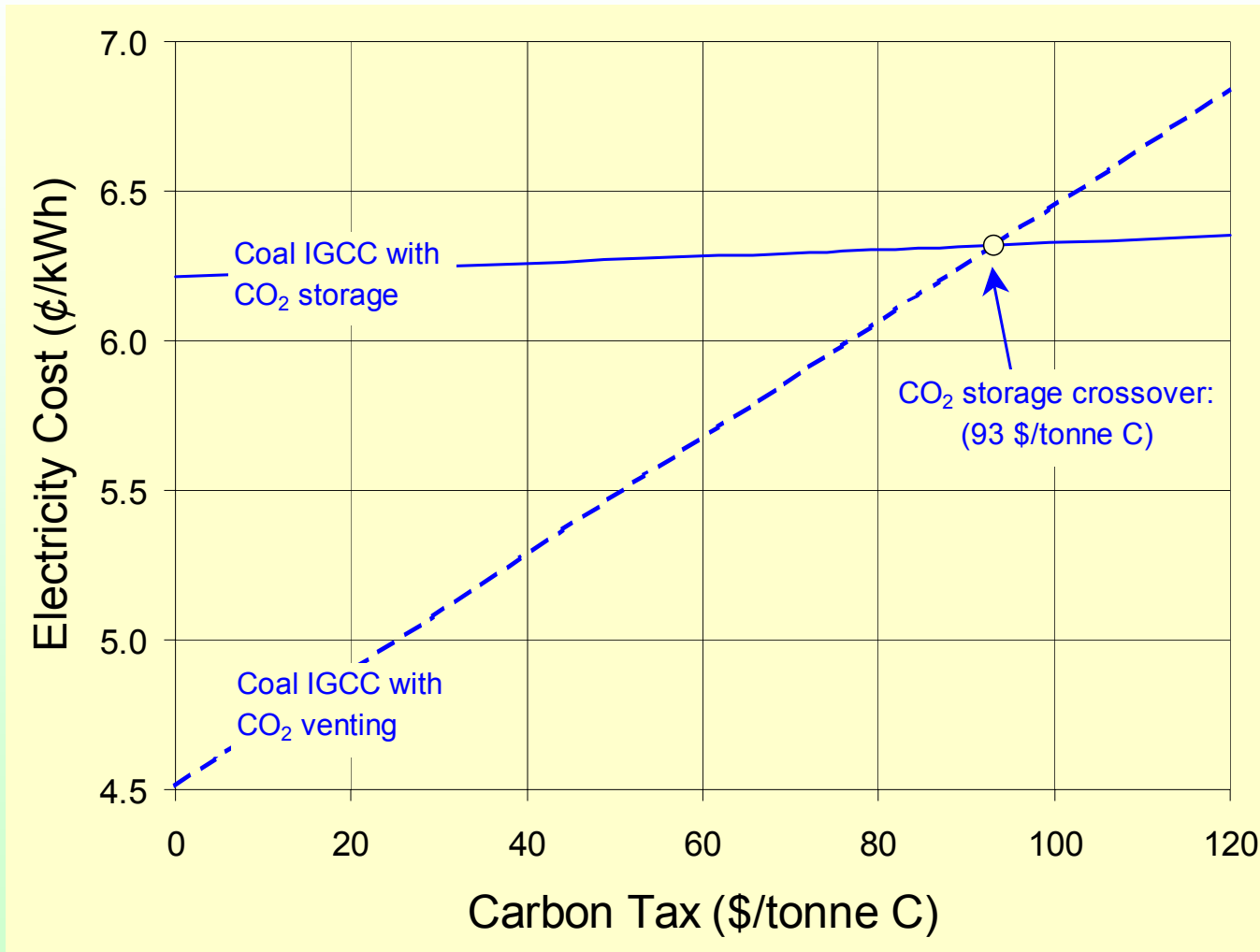

# H<sub>2</sub> Production: Add H<sub>2</sub> Purification/Separation

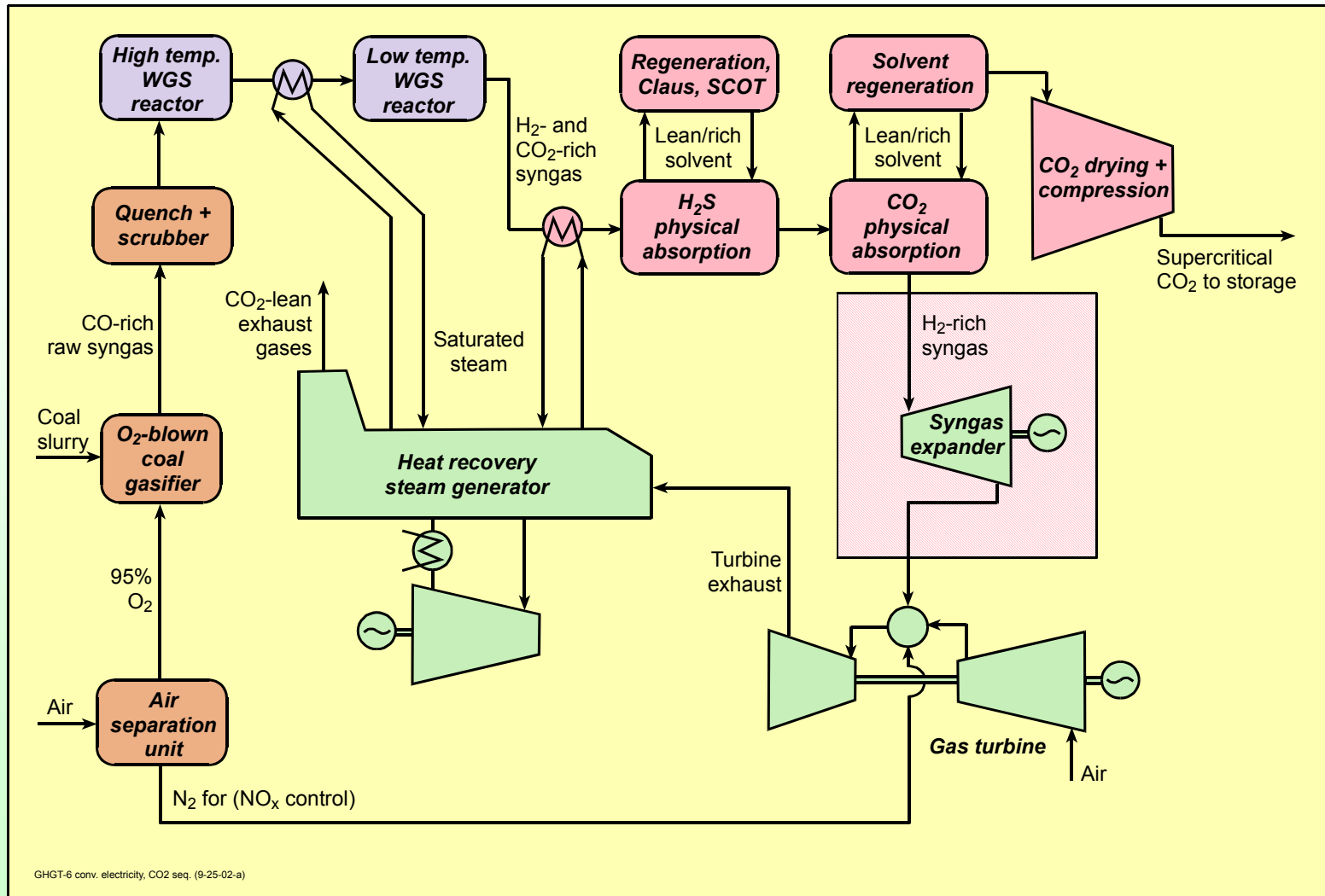

- Replace syngas expander with PSA and purge gas compressor.
- Reduce the size of the gas turbine.

# Conventional $H_2$ Production with $CO_2$ Capture

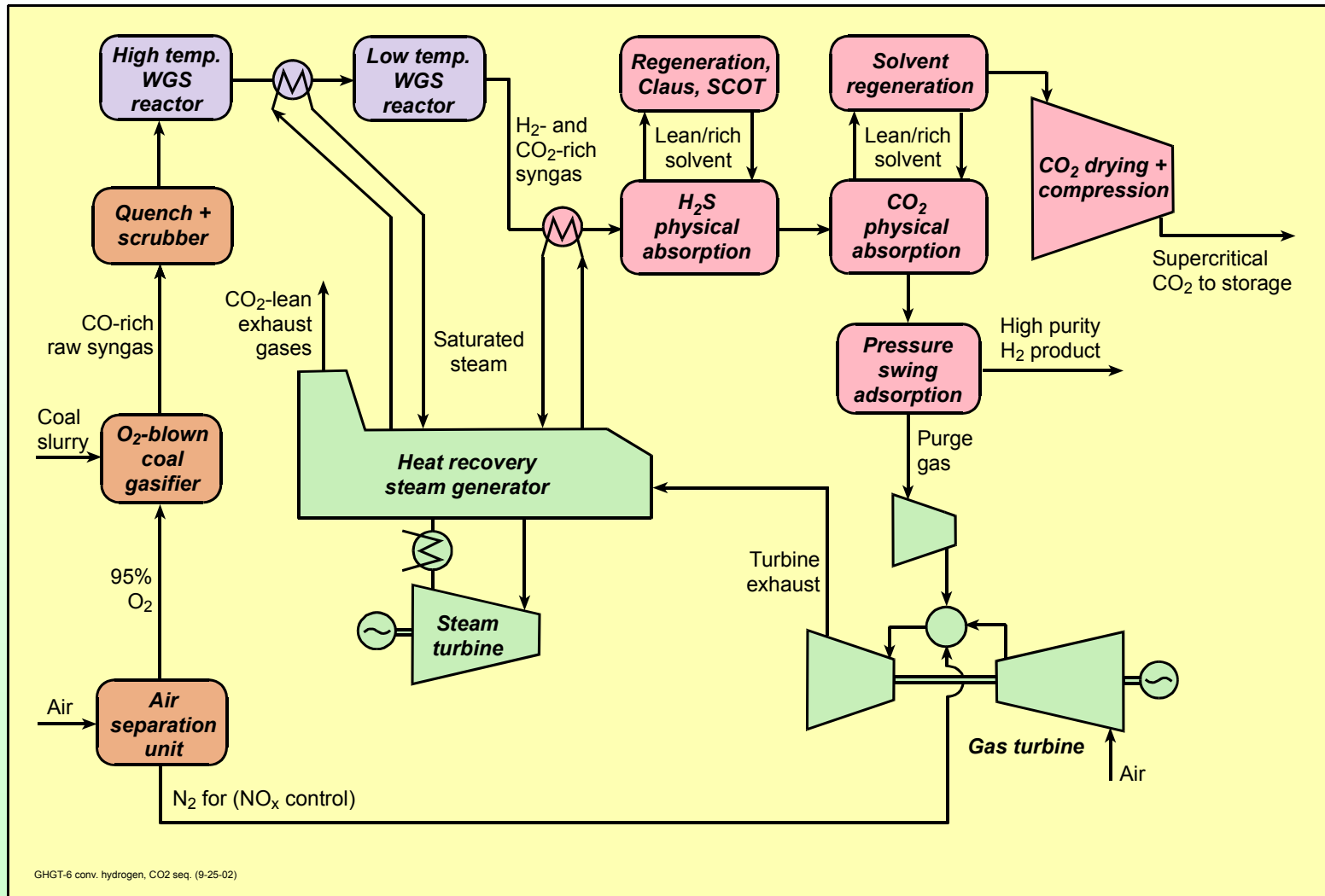

- 1070 MW<sub>th</sub> H<sub>2</sub> (LHV) + 39 MW<sub>e</sub> electricity, efficiency  $\eta^{LHV}=60.9\%$ , 1.03 \$/kg H<sub>2</sub> (no carbon tax). [70 bar gasifier, quench cooling]

# Economics of H<sub>2</sub> from Coal with Carbon Storage

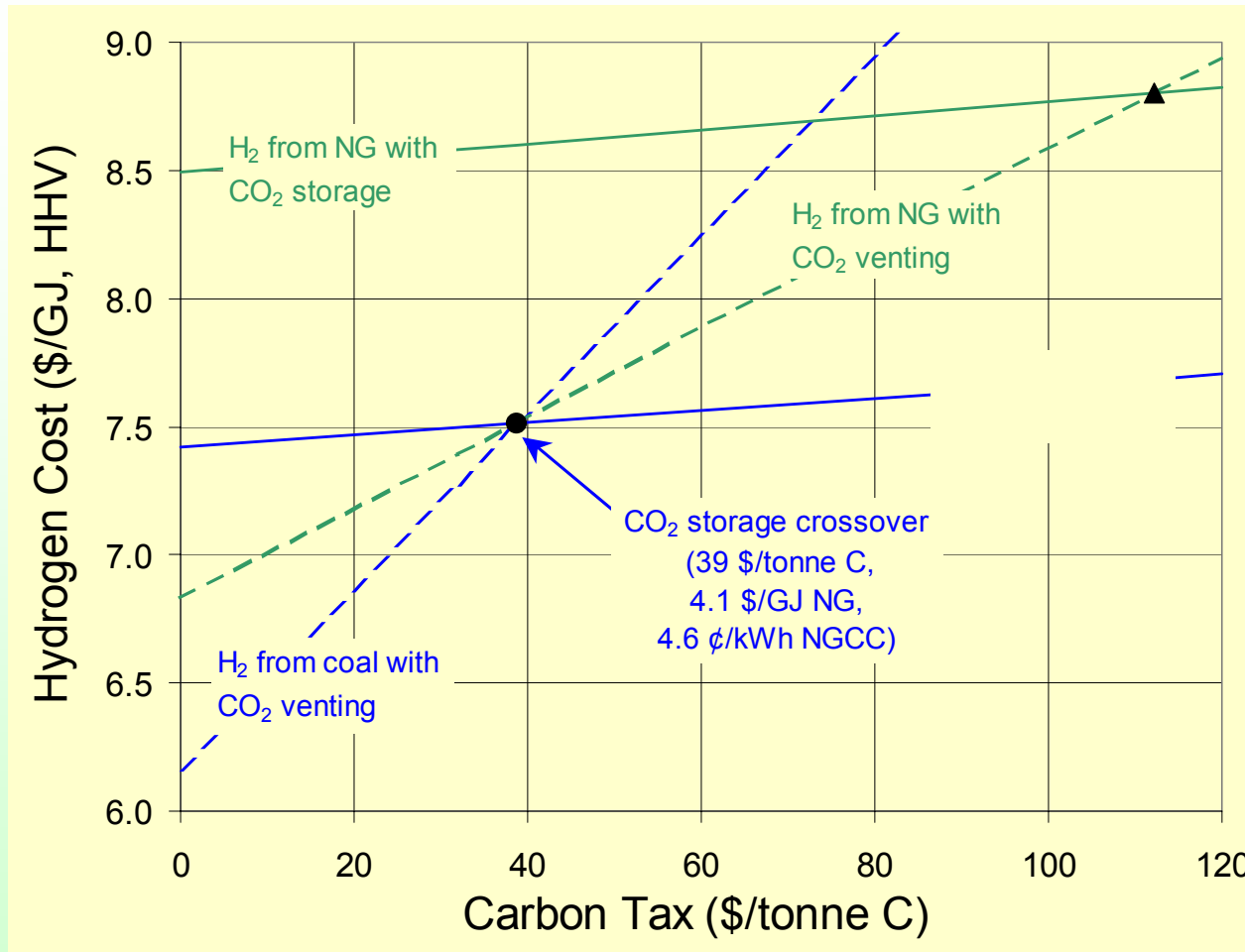

- Both the carbon tax and breakeven NG price needed to induce coal H<sub>2</sub> with CO<sub>2</sub> storage are significantly lower than those for electric power.
- Industrial H<sub>2</sub> from coal might be the earliest CCS opportunity.

# Conventional $H_2$ Production with $CO_2$ Capture

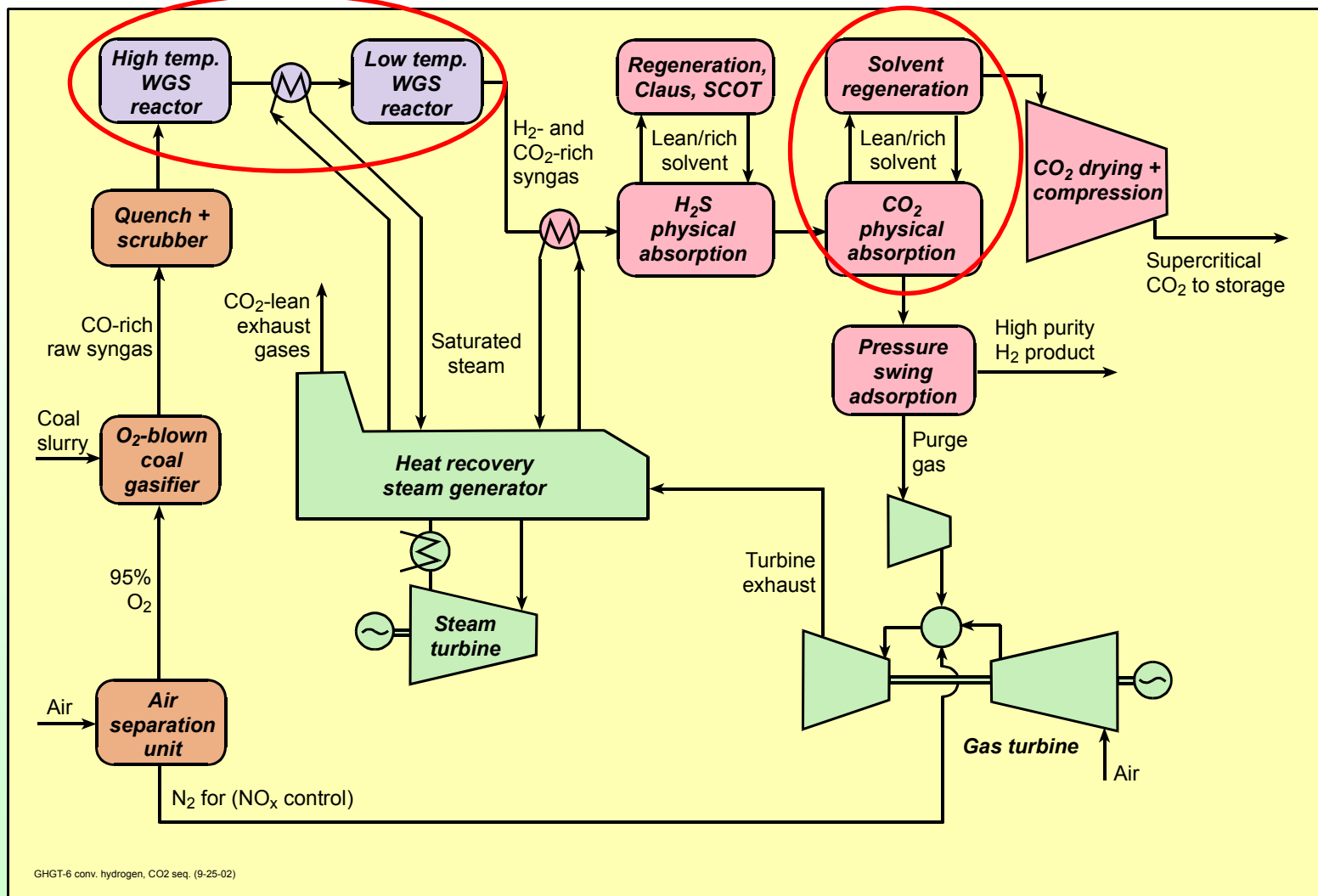

- Incremental cost for CO<sub>2</sub> capture is less for hydrogen than electricity because much of the equipment is already needed for a H<sub>2</sub> plant.



# Conventional $H_2$ Production with $CO_2+H_2S$ Capture

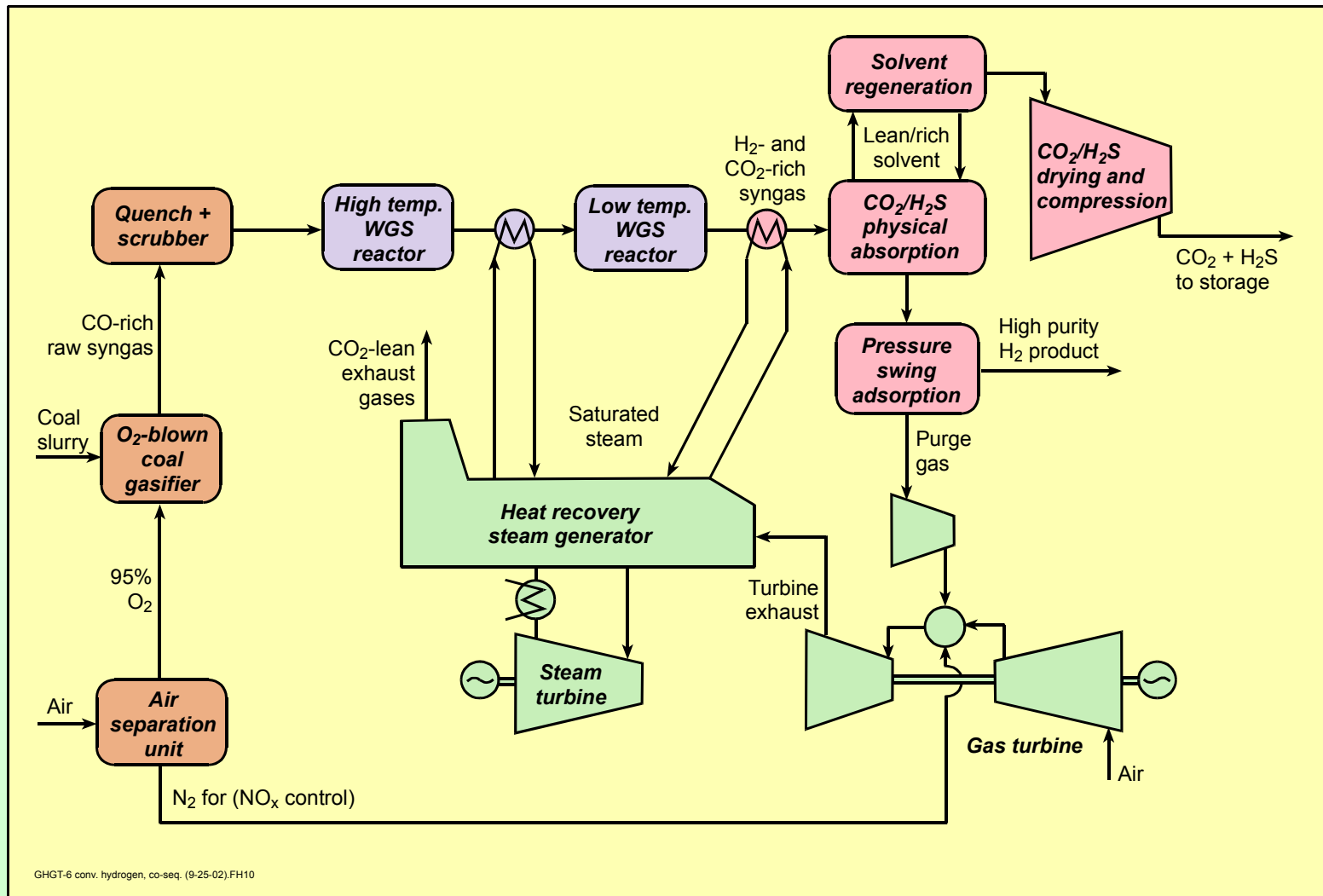

- Resulting system is simpler and cheaper.

# Co-Capture and Co-storage of CO<sub>2</sub> and H<sub>2</sub>S

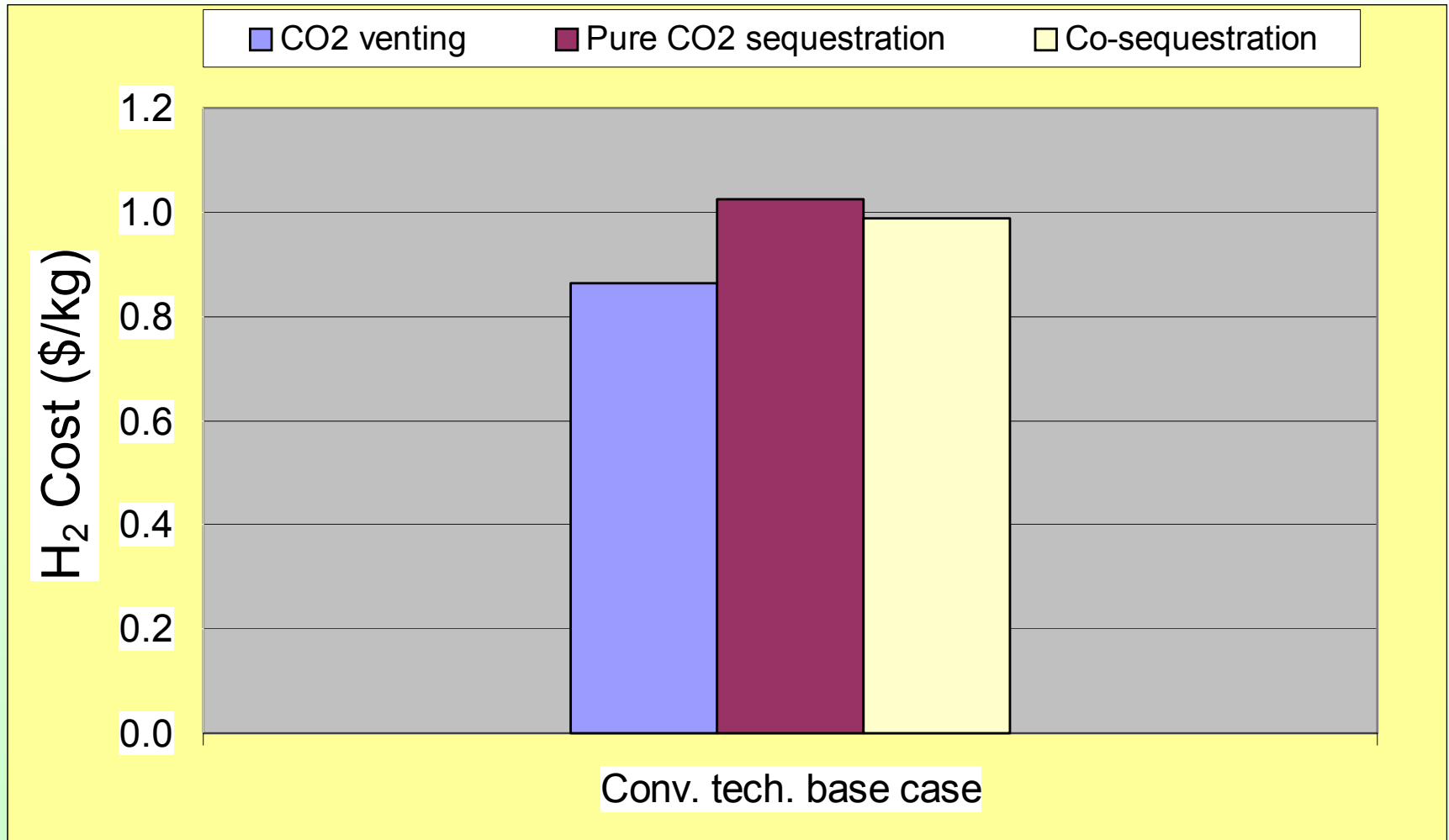

# Economics of H<sub>2</sub> from Coal with H<sub>2</sub>S-CO<sub>2</sub> Co-Storage

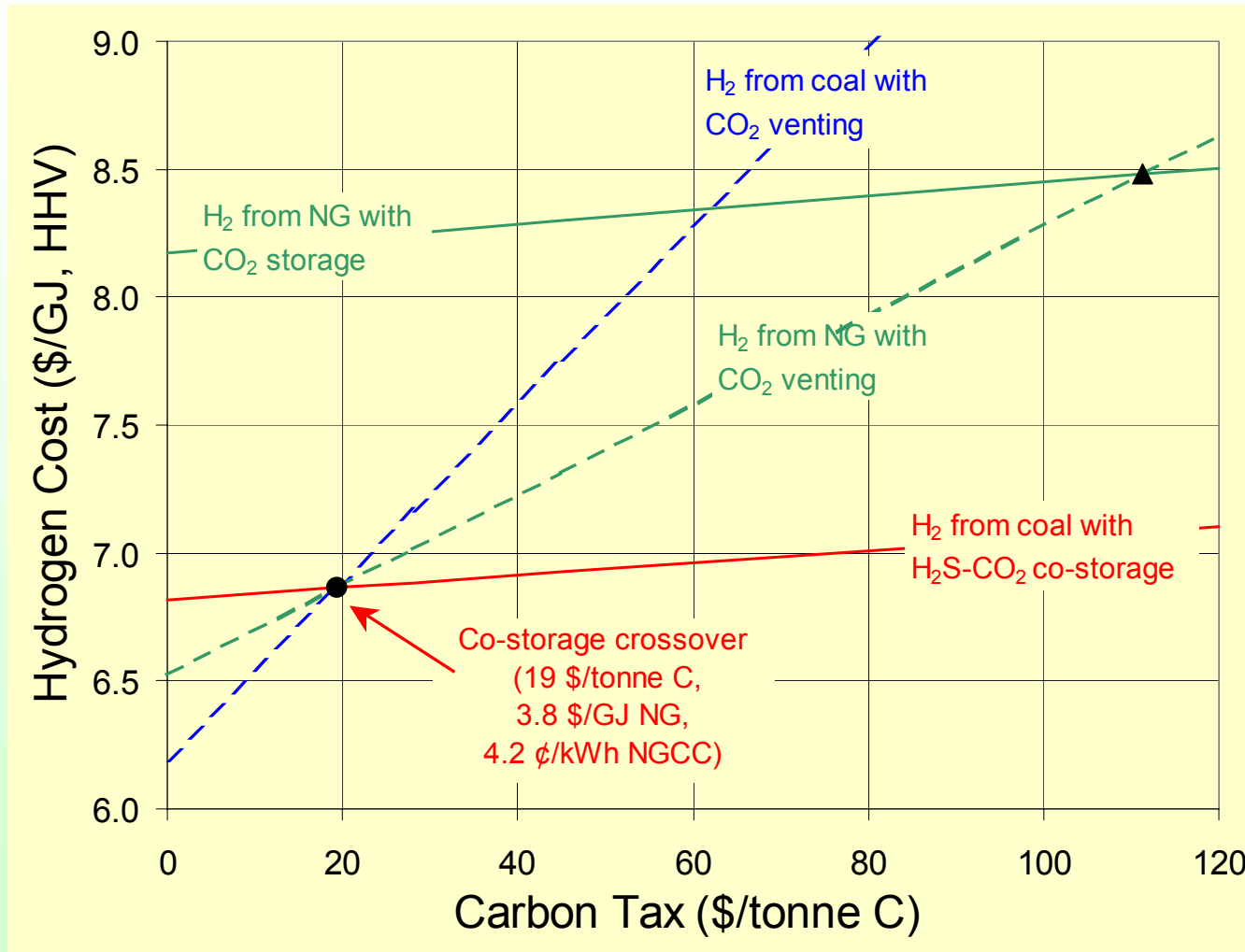

- H<sub>2</sub>S-CO<sub>2</sub> co-storage further reduces both the crossover carbon tax and breakeven NG price.

# Produce "Fuel Grade" $H_2$ with $CO_2+H_2S$ Capture

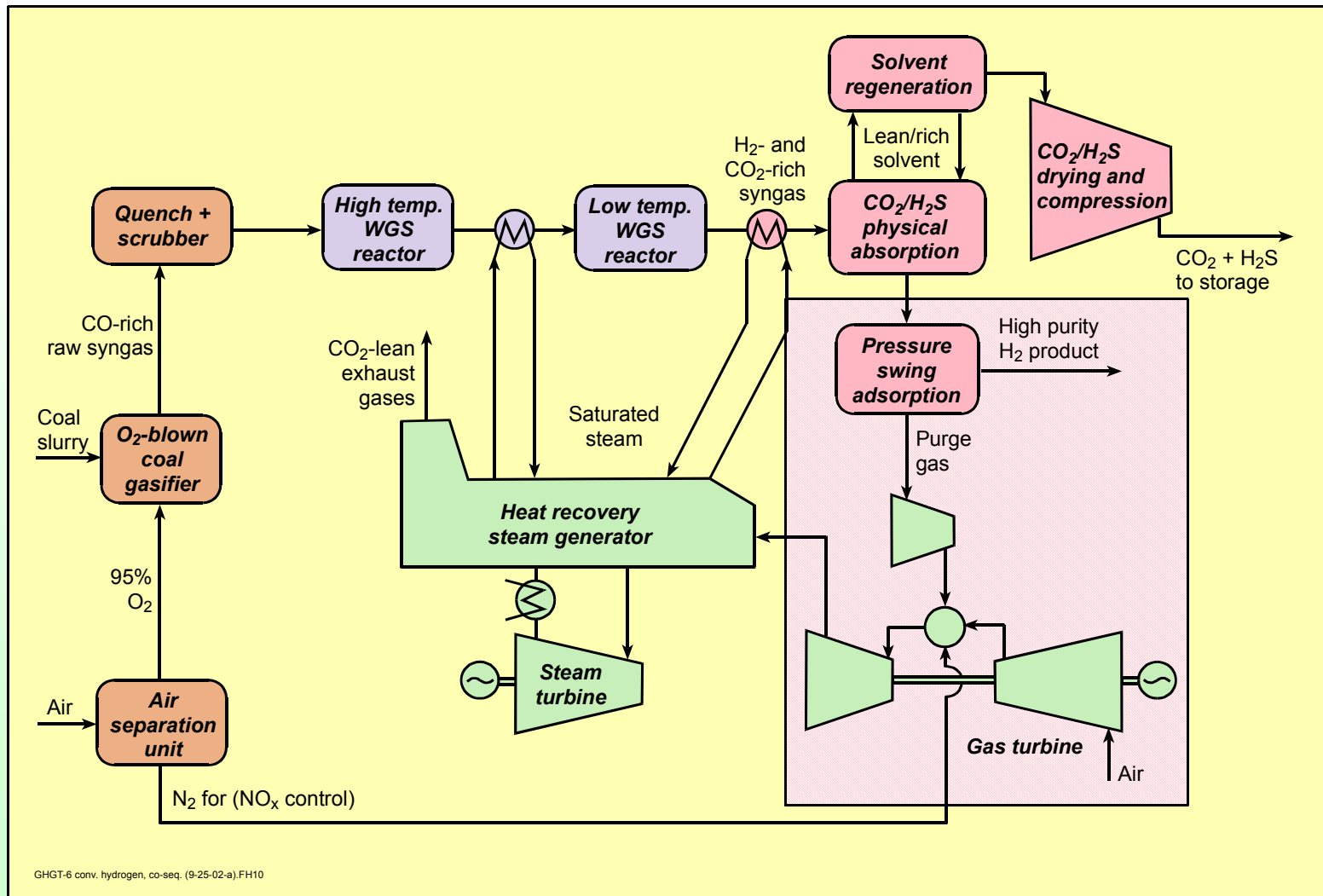

- Remove the PSA and gas turbine; smaller steam cycle.

# “Fuel Grade” (~93% pure) $H_2$ with $CO_2/H_2S$ Capture

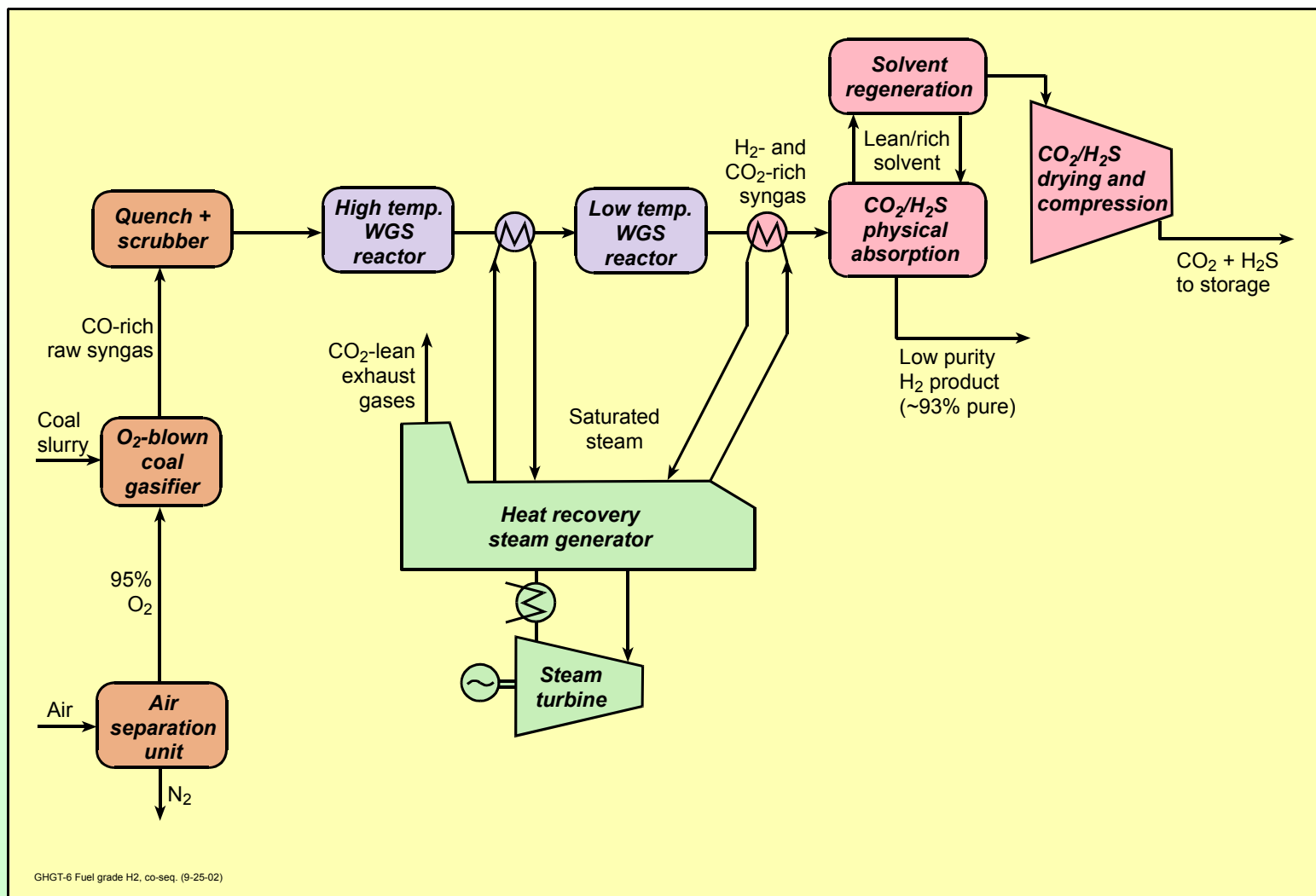

- Simpler, less expensive plant. No novel technology needed.

# Production of “Fuel Grade” H<sub>2</sub>

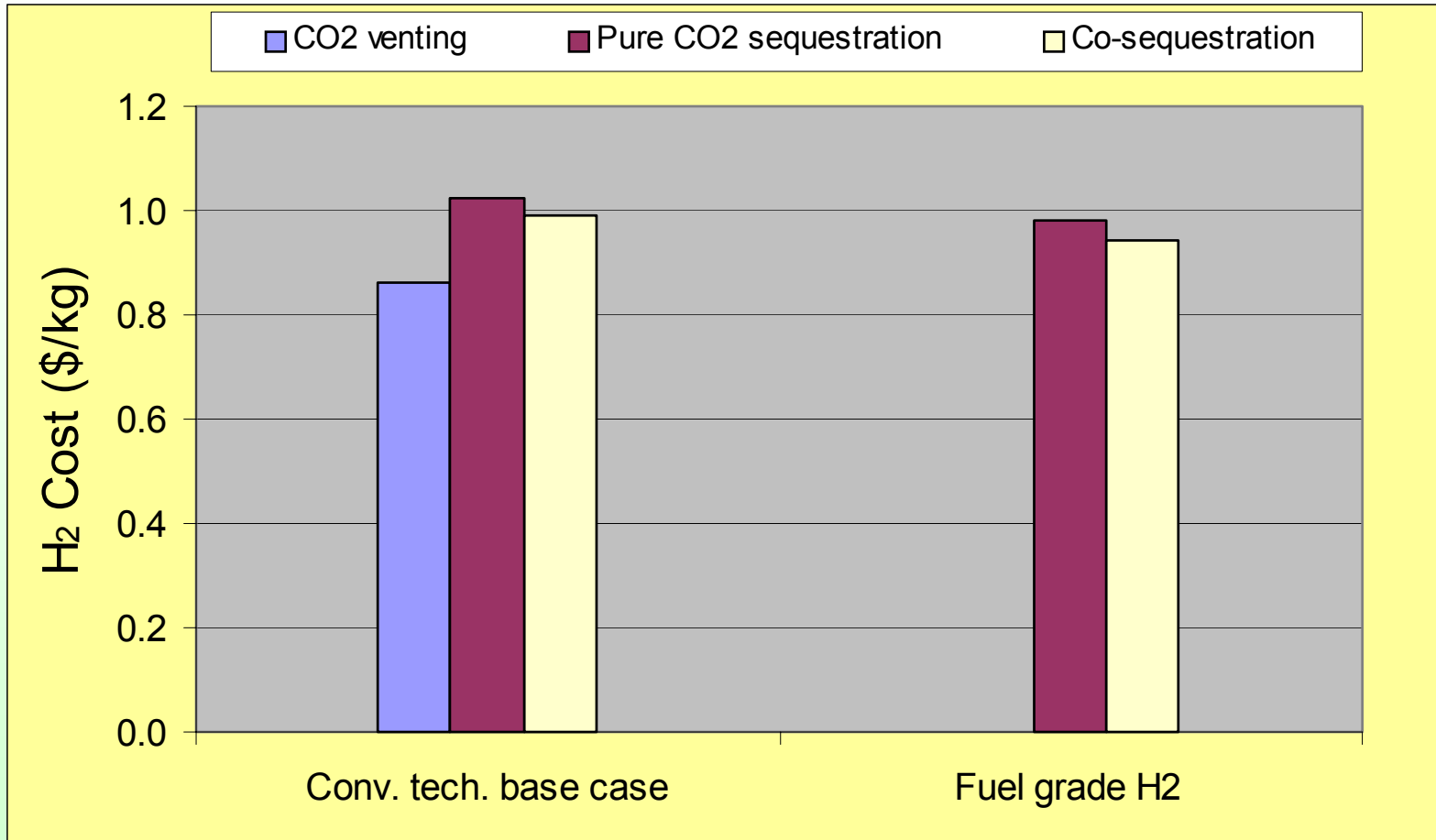

- Fuel grade H<sub>2</sub> more competitive with gas and oil in the heating sector, and might be adequate for transportation (H<sub>2</sub> ICEVs; barrier to PEM FCEVs?)

# Change $H_2$ - $CO_2$ Gas Separation Scheme

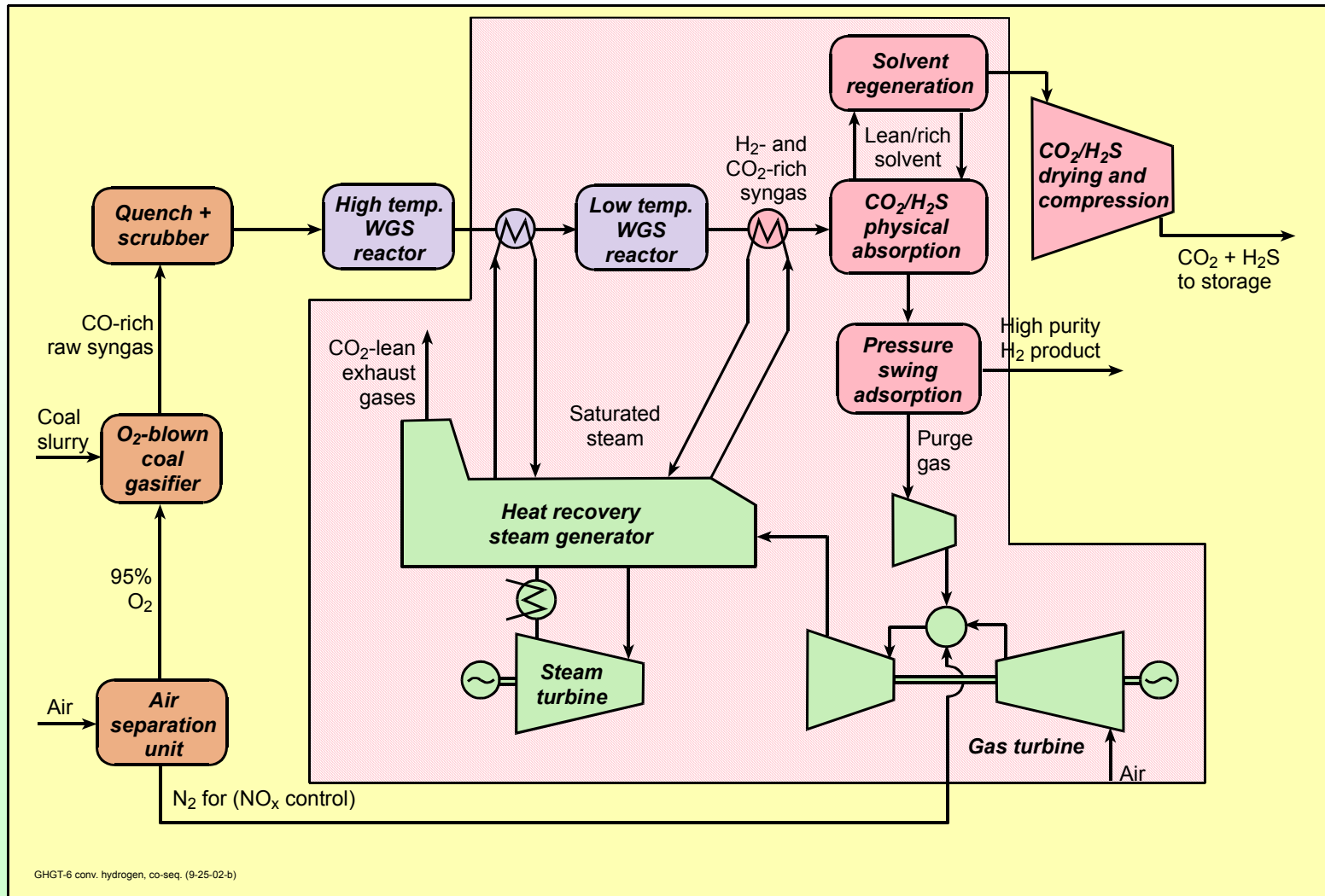

- This work uses a membrane to separate  $H_2$  from the syngas instead of  $CO_2$ .

# H<sub>2</sub> Separation Membrane Reactor System

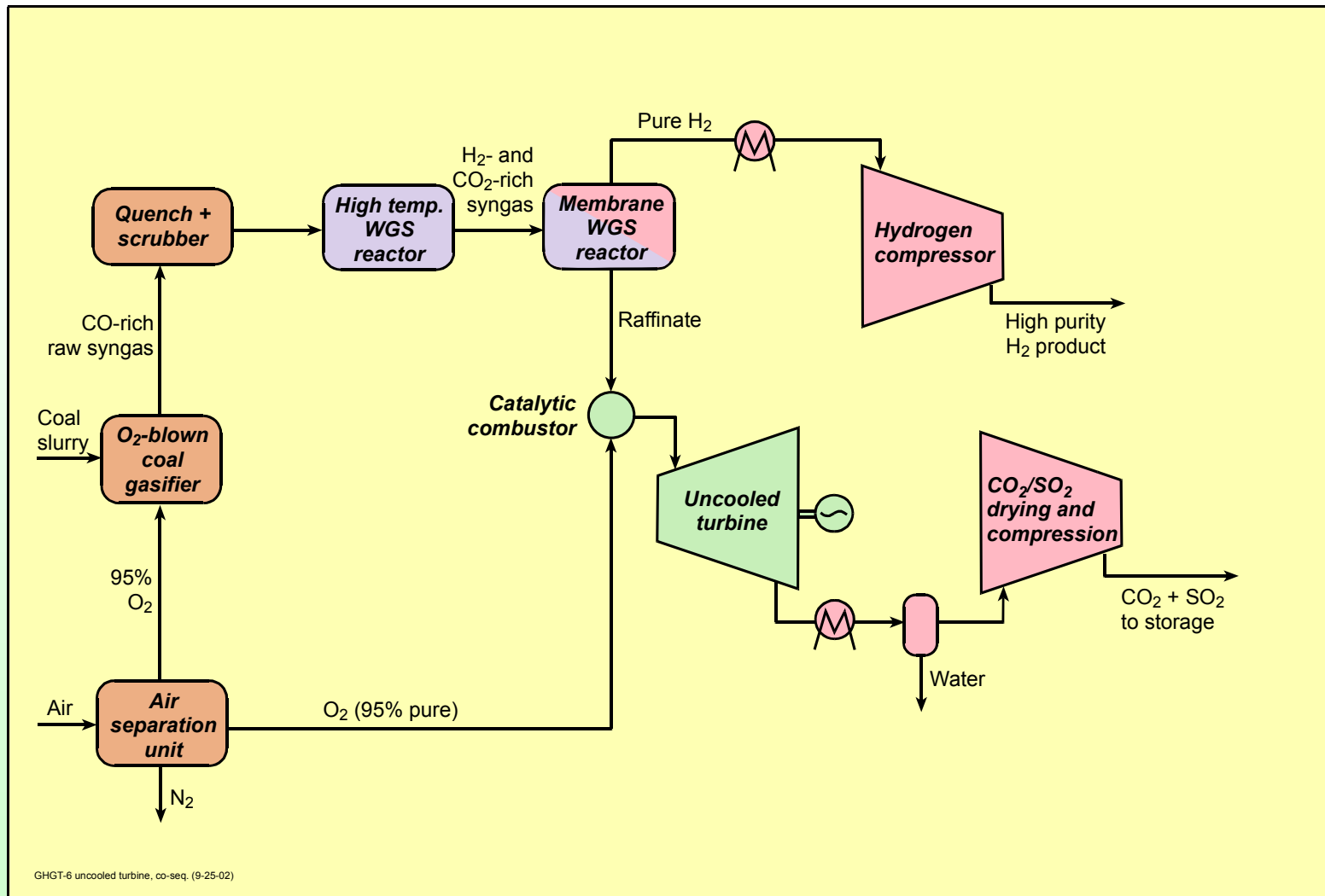

- Employ a H<sub>2</sub> permeable, thin film (10 μm), 60/40% Pd/Cu (sulfur tolerant) dense metallic membrane, configured as a WGS membrane reactor.

# Hydrogen Separation Membrane Reactor (HSMR) Concept

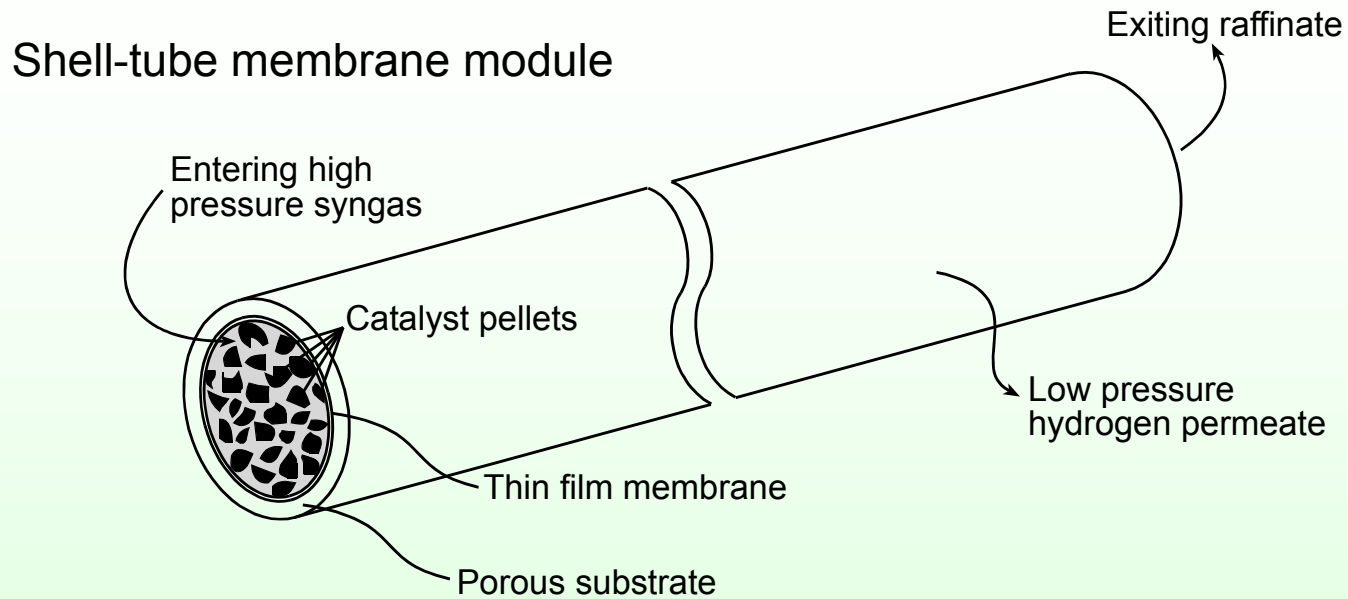

## Membrane Structure:

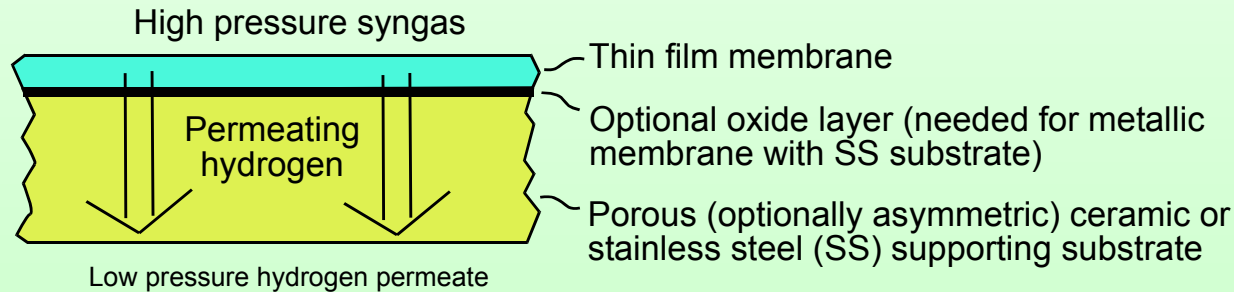

Membrane Reactor 5 5-3-03

- Alternative HSMR design: high pressure, WGS reaction, and membrane *outside* supporting tube, with  $H_2$  permeating to the interior of the tube

# Typical Membrane Reactor Performance

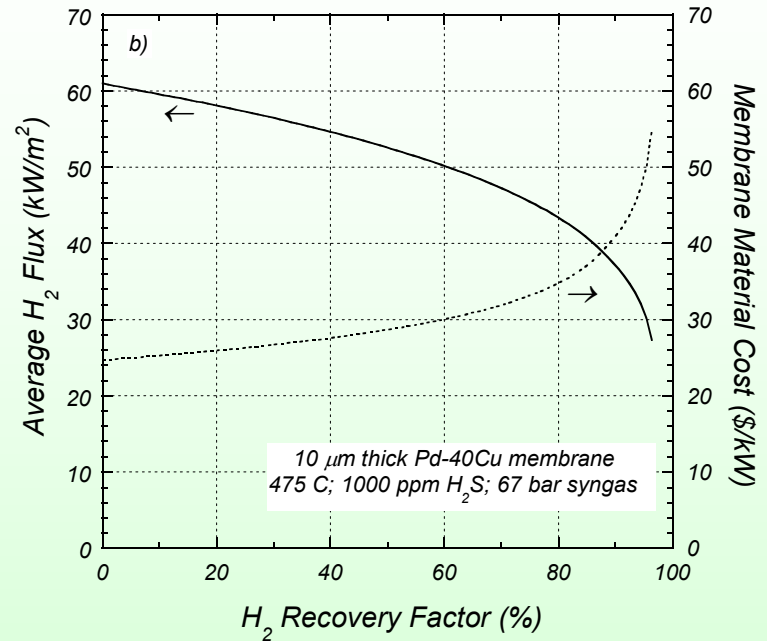
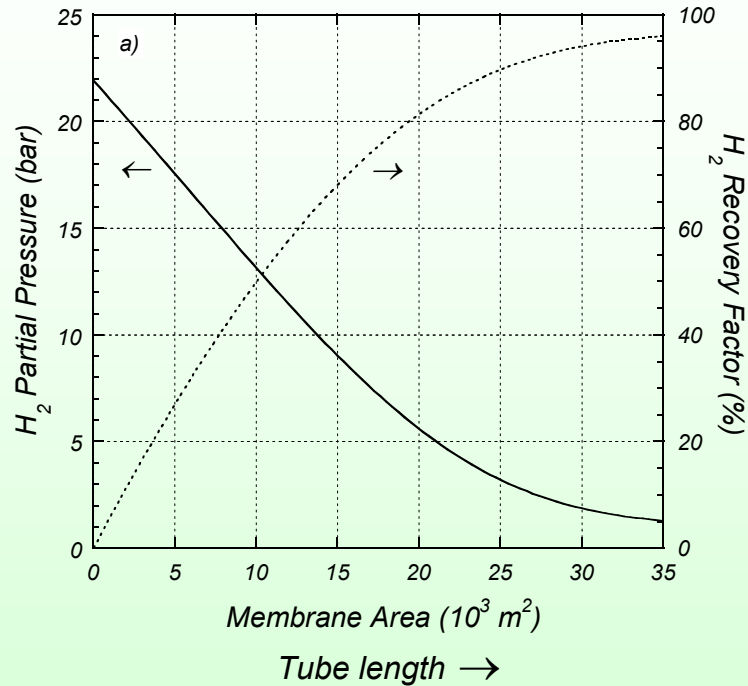

- H<sub>2</sub> Recovery Factor (HRF) = H<sub>2</sub> recovered / (H<sub>2</sub>+CO) in syngas
- HRF increases with membrane area → **diminishing returns**
- Membrane costs rise sharply above HRF~80-90% (no sweep gas)

# Cost of $H_2$ Compression and HSMR vs. $H_2$ Backpressure

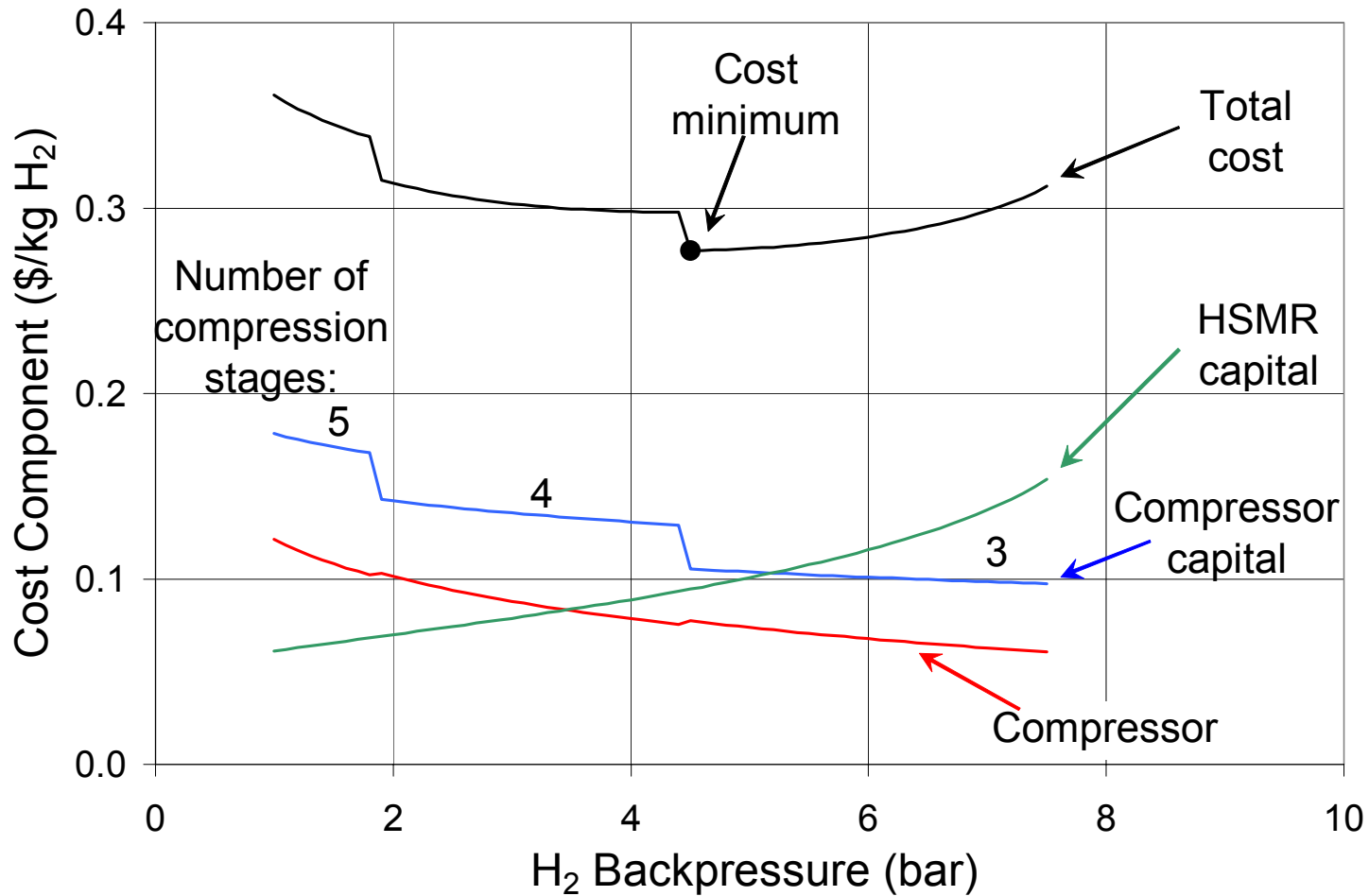



# Membrane System Results Summary

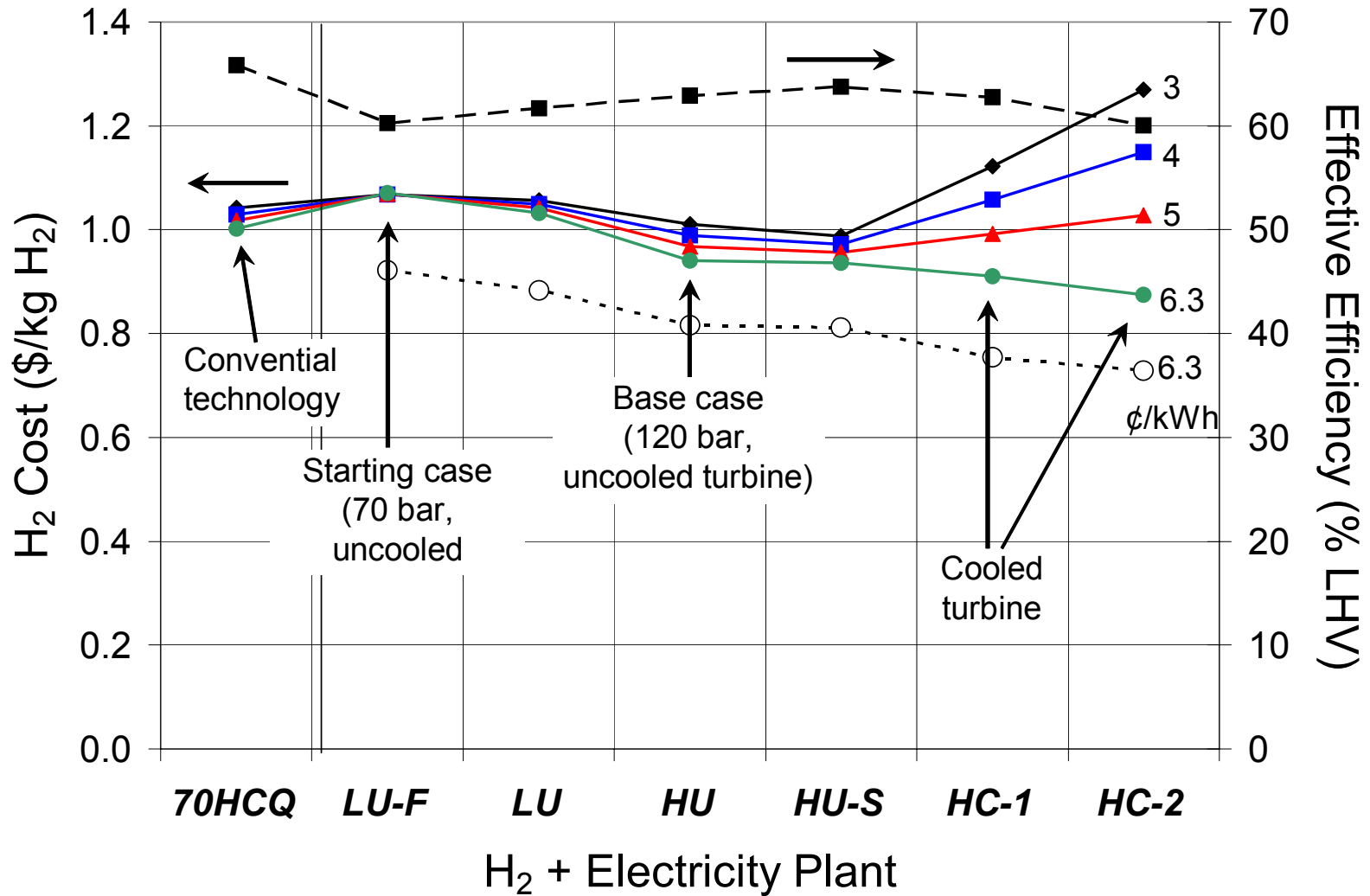

# Part 1 Summary

- No matter how hard we try, H<sub>2</sub> costs \$1/kg!

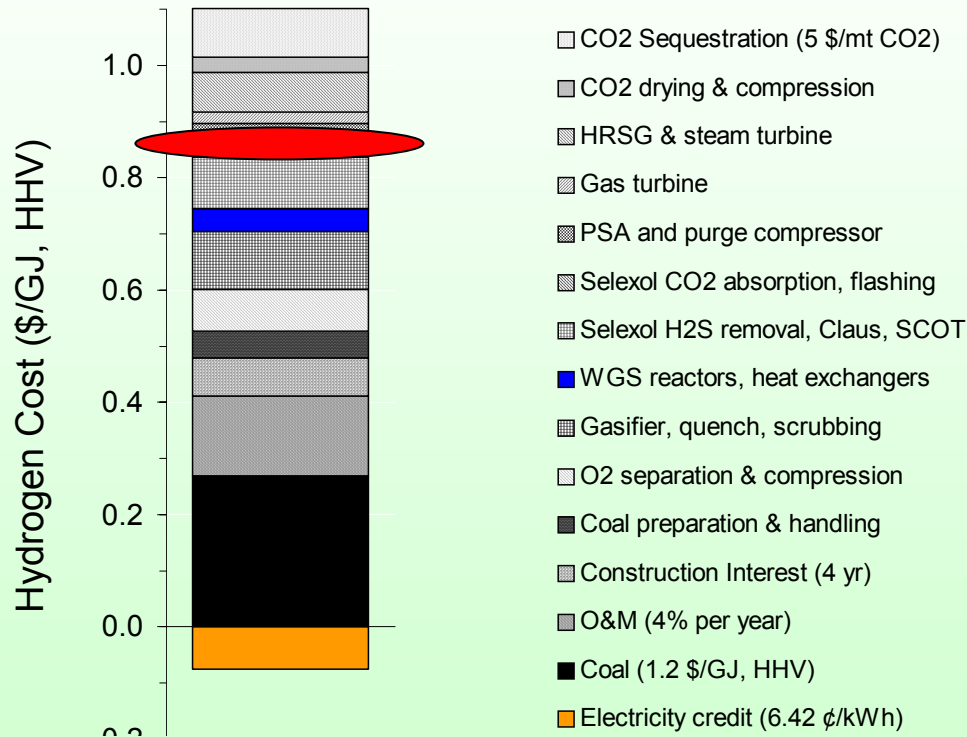

- *Question:* Would the world's outlook be significantly enhanced if H<sub>2</sub> cost 90 ¢/kg? 80 ¢/kg?

# *Outline of Talk*

- Overview of our work on production of carbon-free H<sub>2</sub> and electricity from fossil fuels (primarily coal)
- Putting our work in perspective
- Areas of interest for future work

# Where Might H<sub>2</sub> be Used?

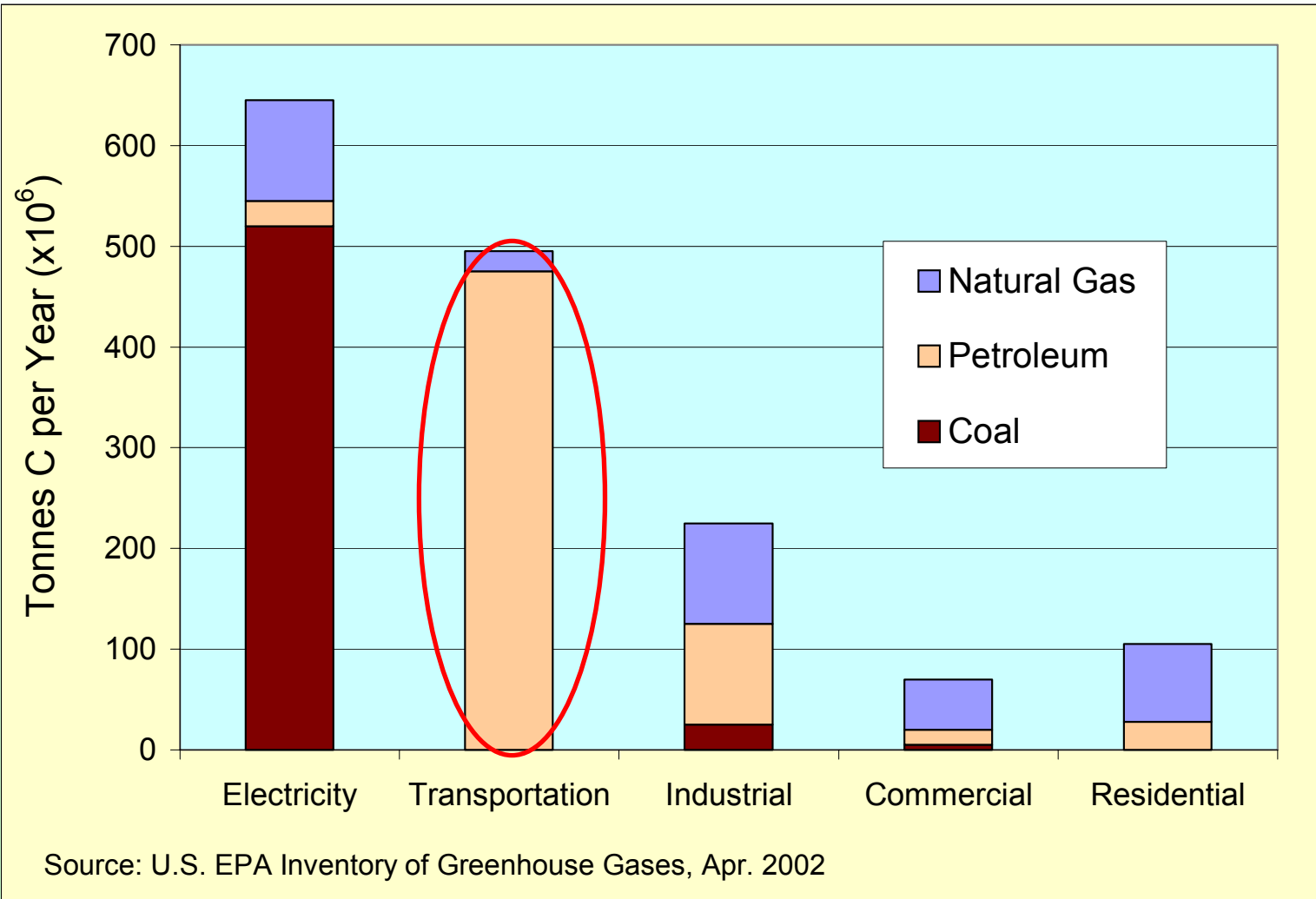

# Production Cost of $H_2$ (Scale=1 $GW_{th}$ HHV)

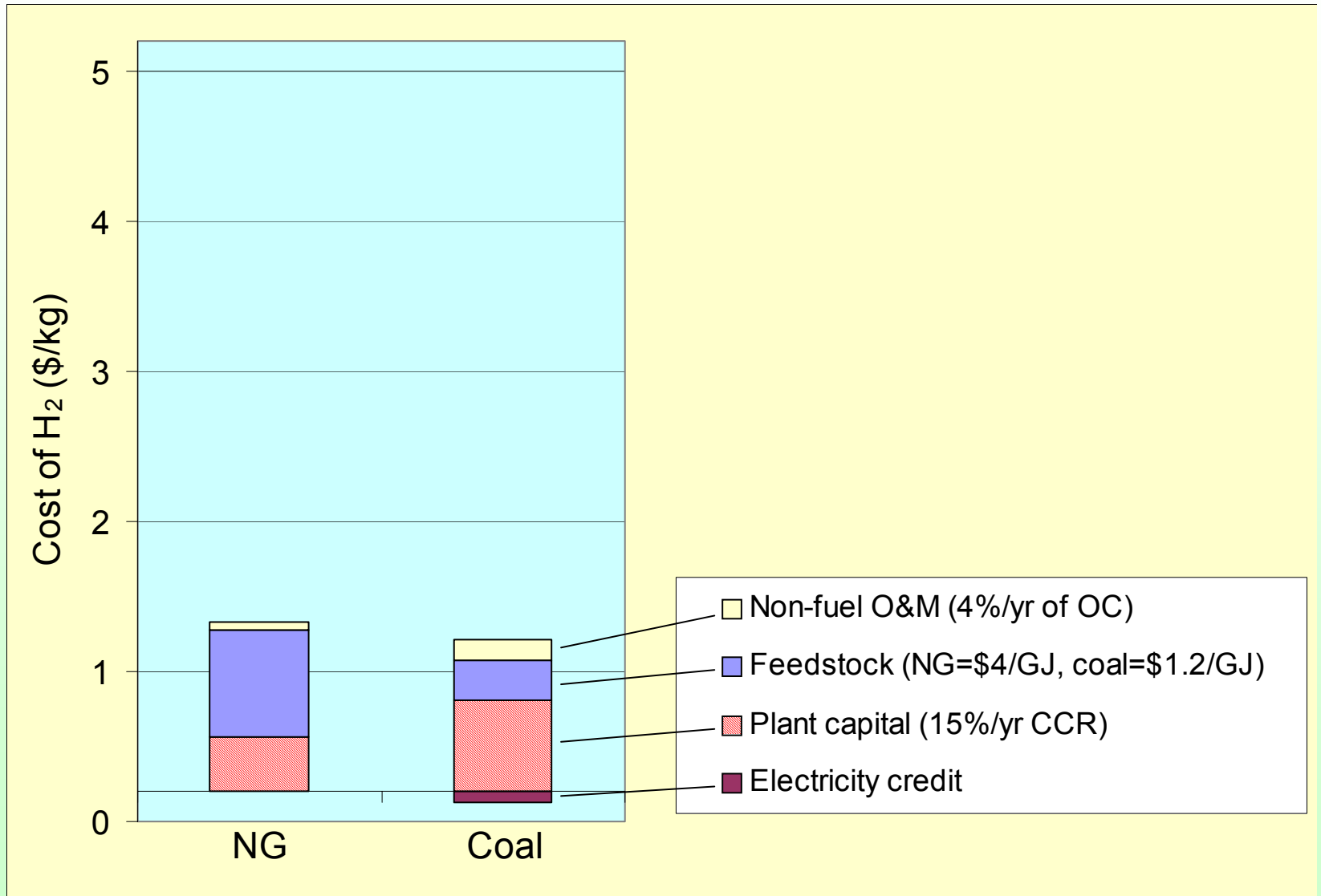

# Add CO<sub>2</sub> Transport and Geologic Storage...

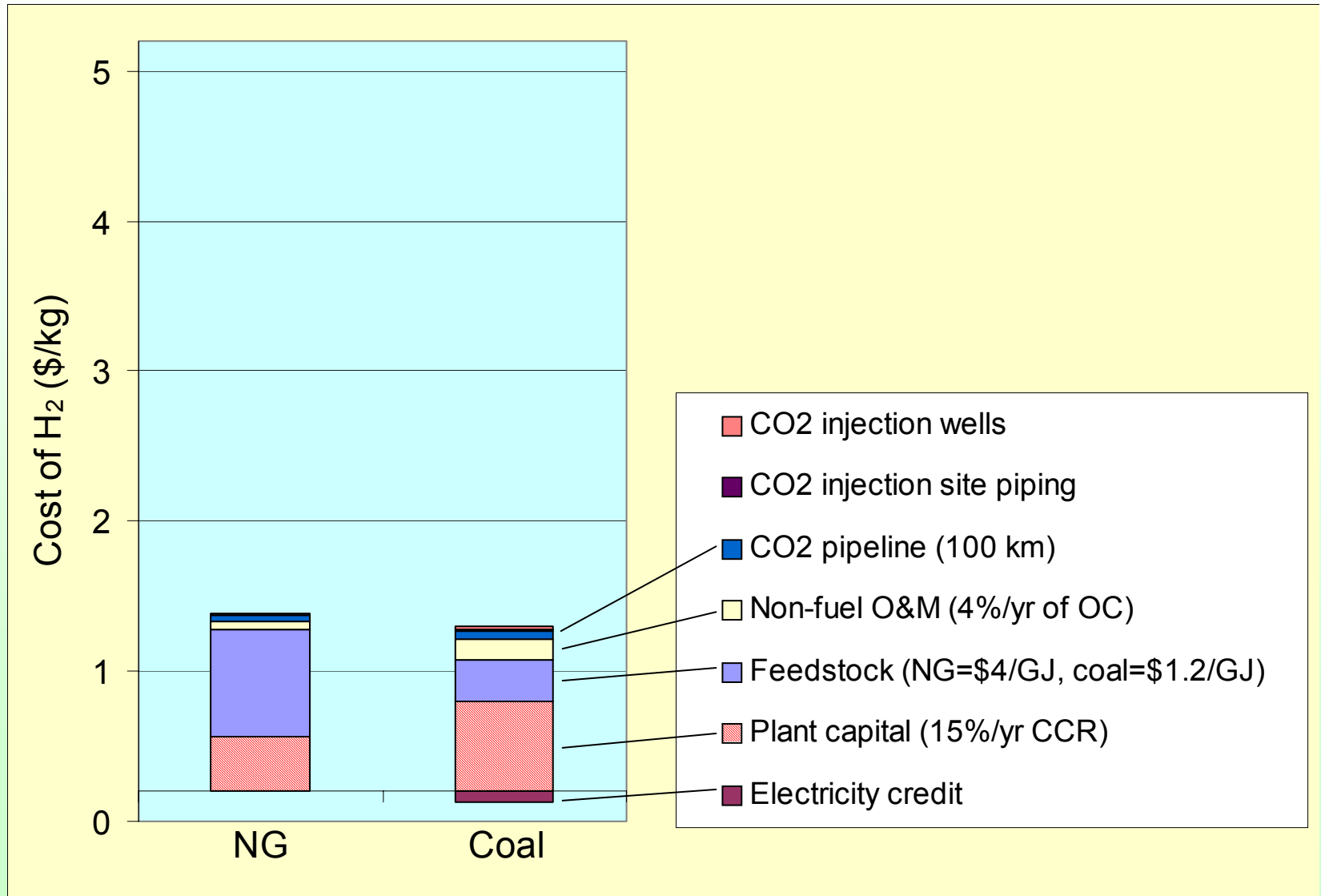

# Add H<sub>2</sub> Storage and Distribution Pipelines...

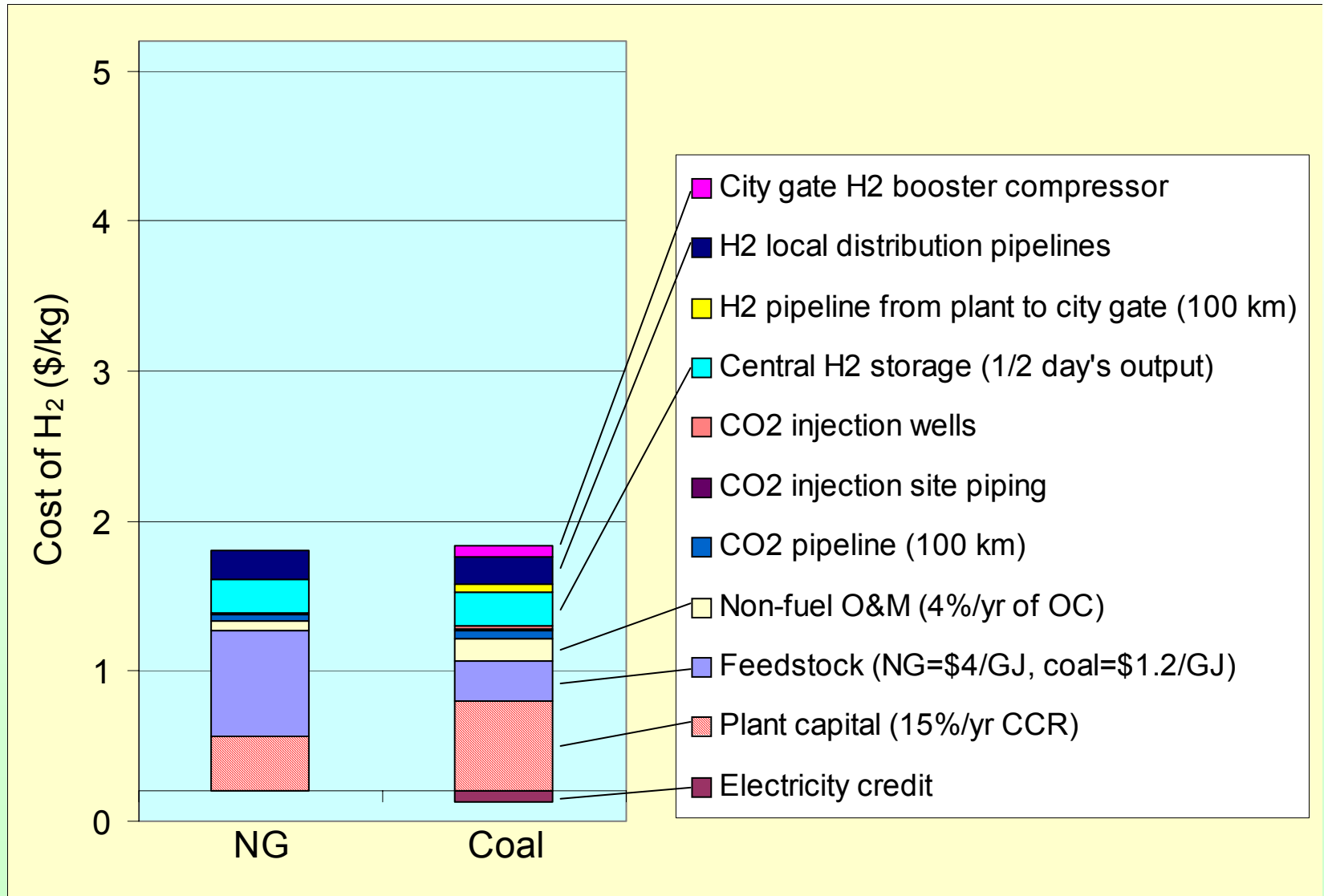

# Add H<sub>2</sub> Refueling Stations...

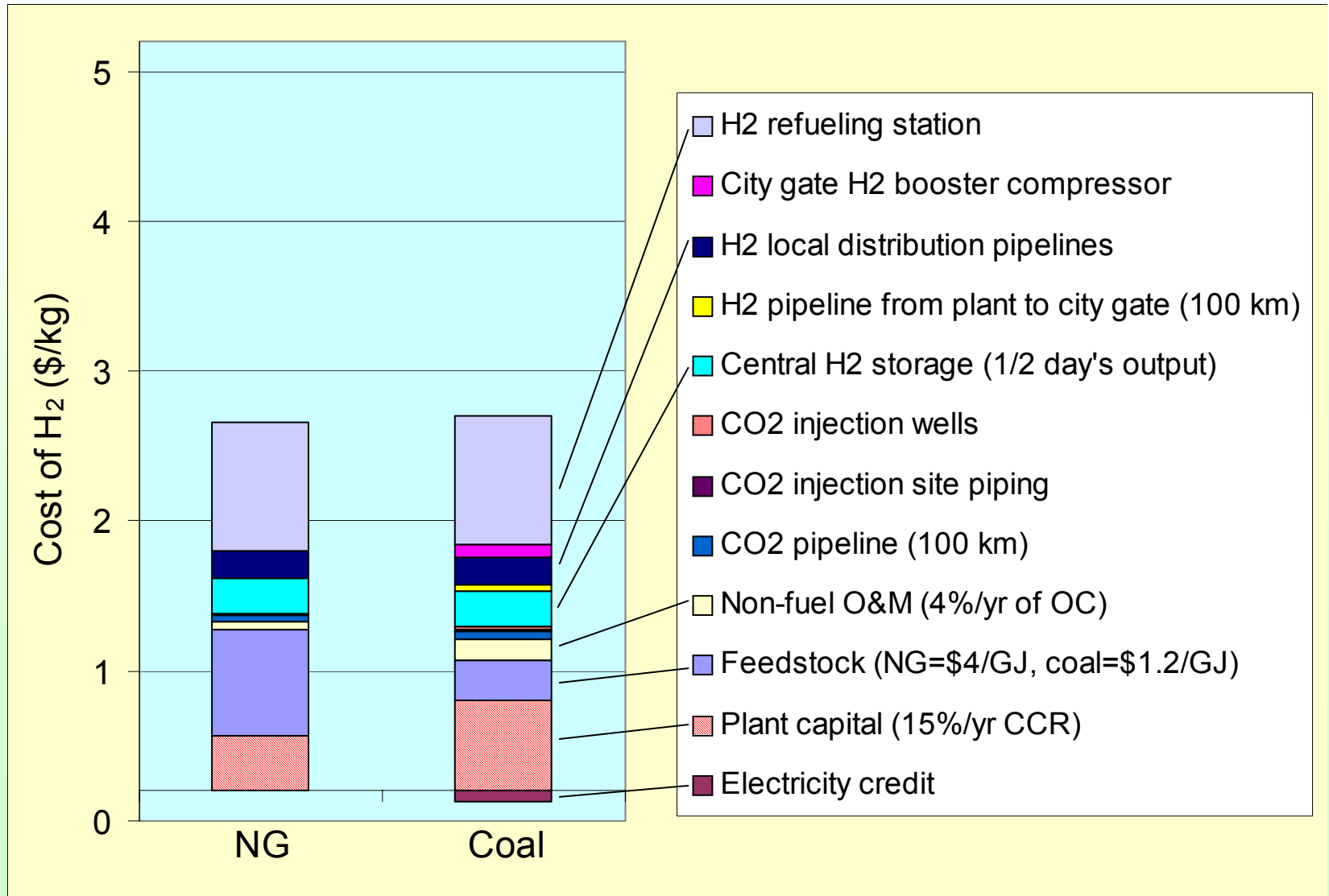

# Add the Incremental Vehicle Cost...

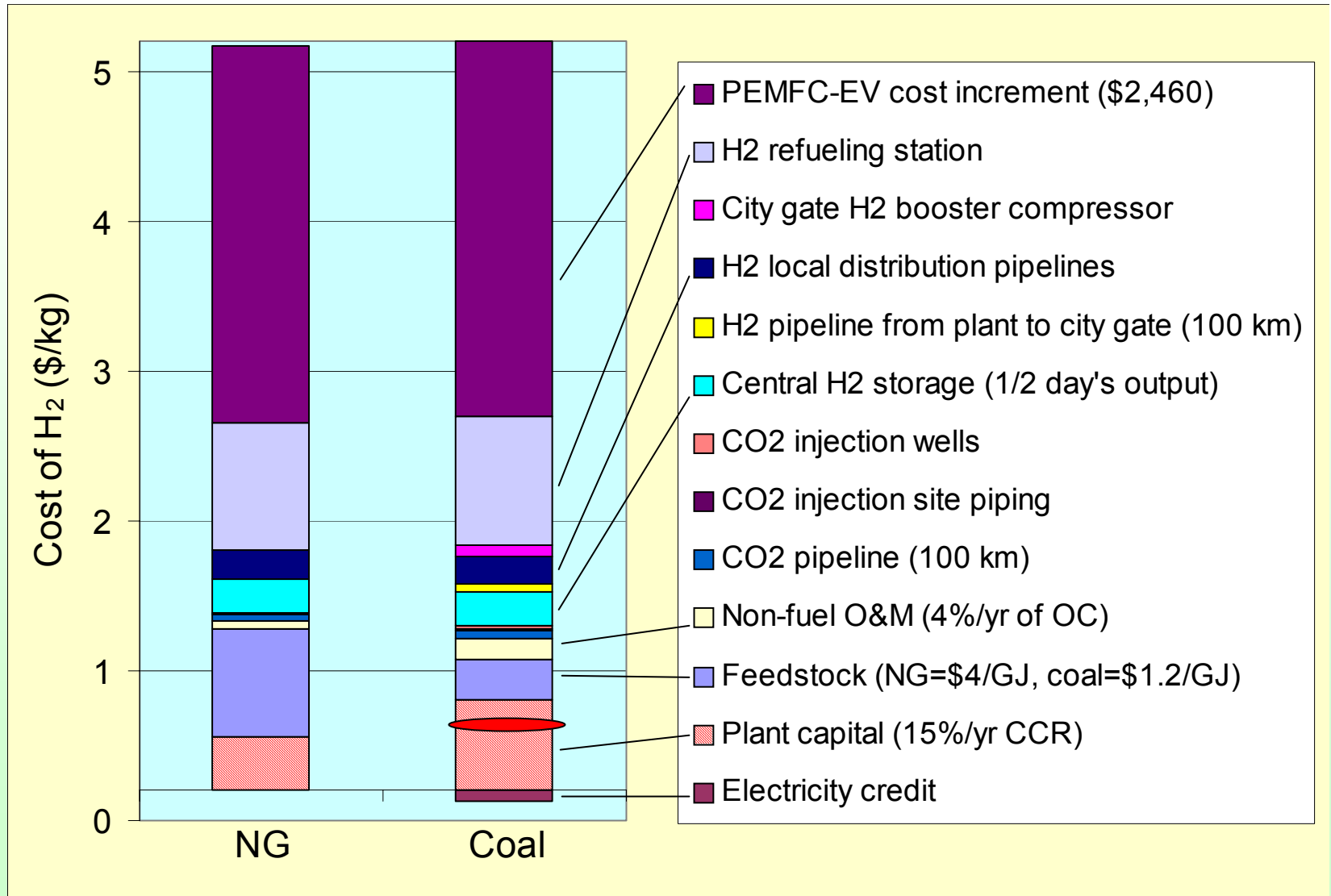

# Where Else Might $H_2$ be Used?

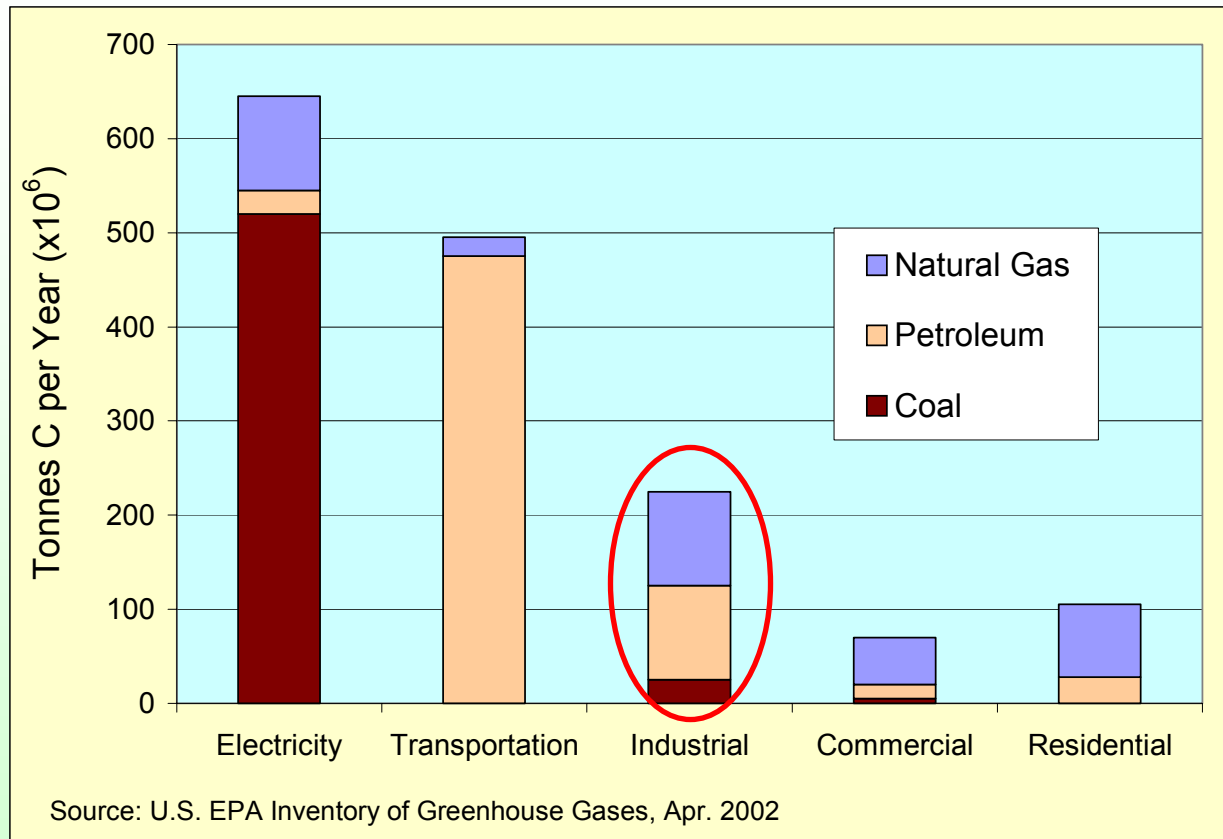

- Displacing traditional  $H_2$  from NG (1% of global primary energy).
- At 200 \$/tonne C,  $H_2$  for industrial boilers, furnaces, and kilns becomes competitive with gas at 4 \$/GJ. Oil?

# *Outline of Talk*

- Overview of our work on production of carbon-free H<sub>2</sub> and electricity from fossil fuels (primarily coal)
- Putting our work in perspective
- Areas of interest for future work

# *What is this Curve?*

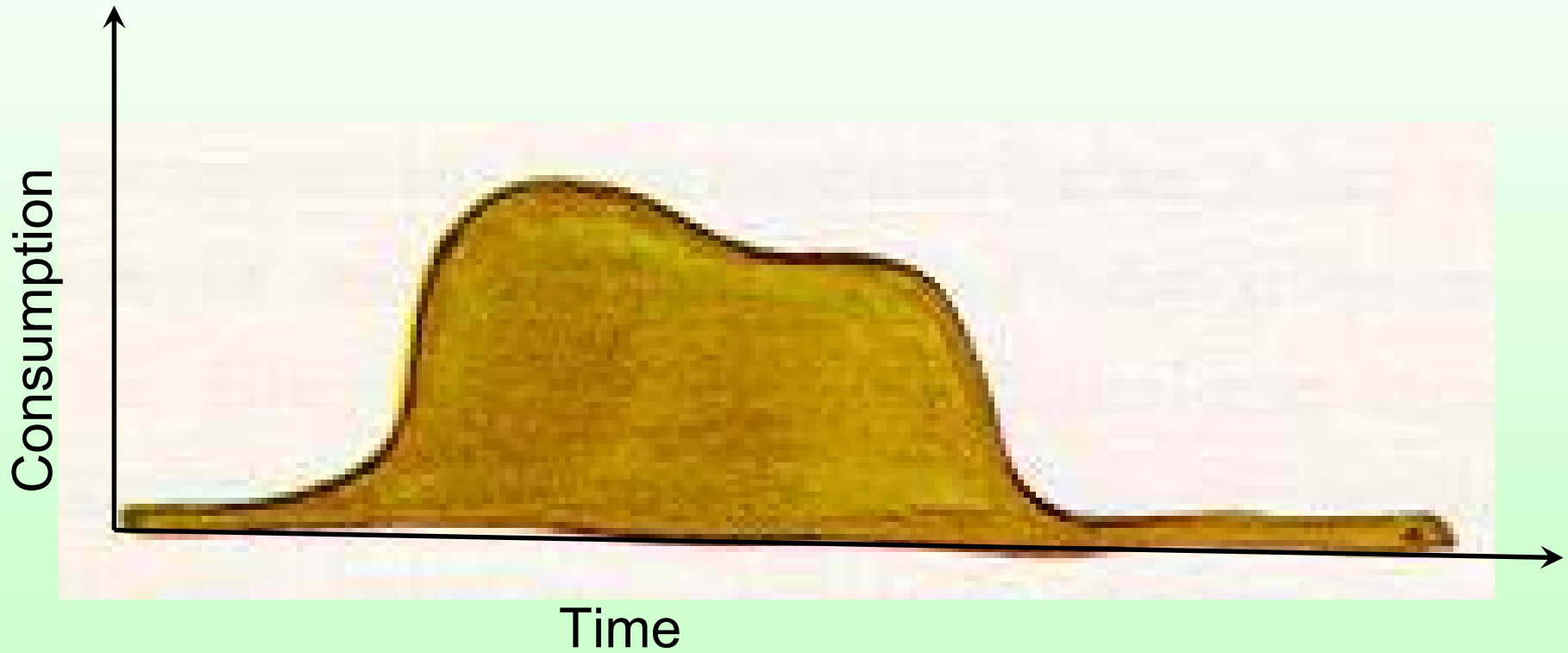

# *The “Elephant-in-the-Snake” Problem*

*or*

*“How does Ohio absorb a 1 GW<sub>th</sub> H<sub>2</sub> plant?”*

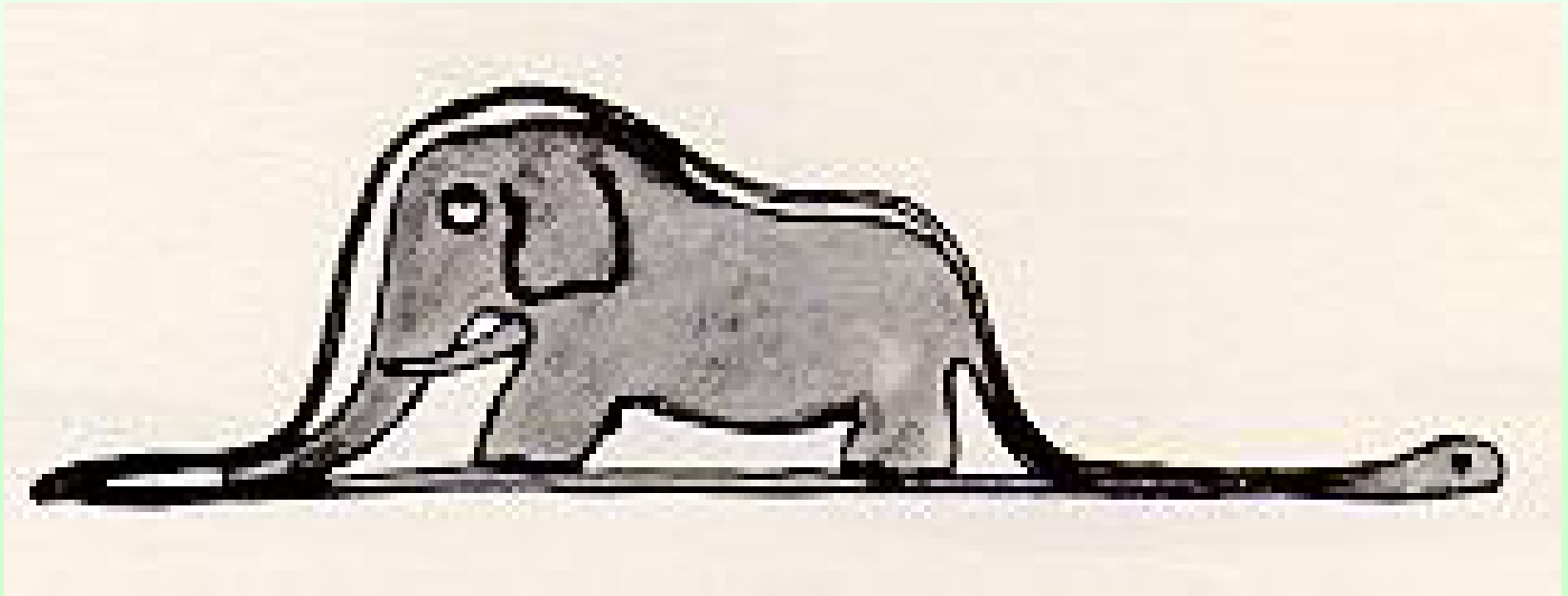

*“Le Petit Prince”, Antoine de Saint Exupéry*

# CASE STUDY - OHIO YEAR 10 HYDROGEN DEMAND

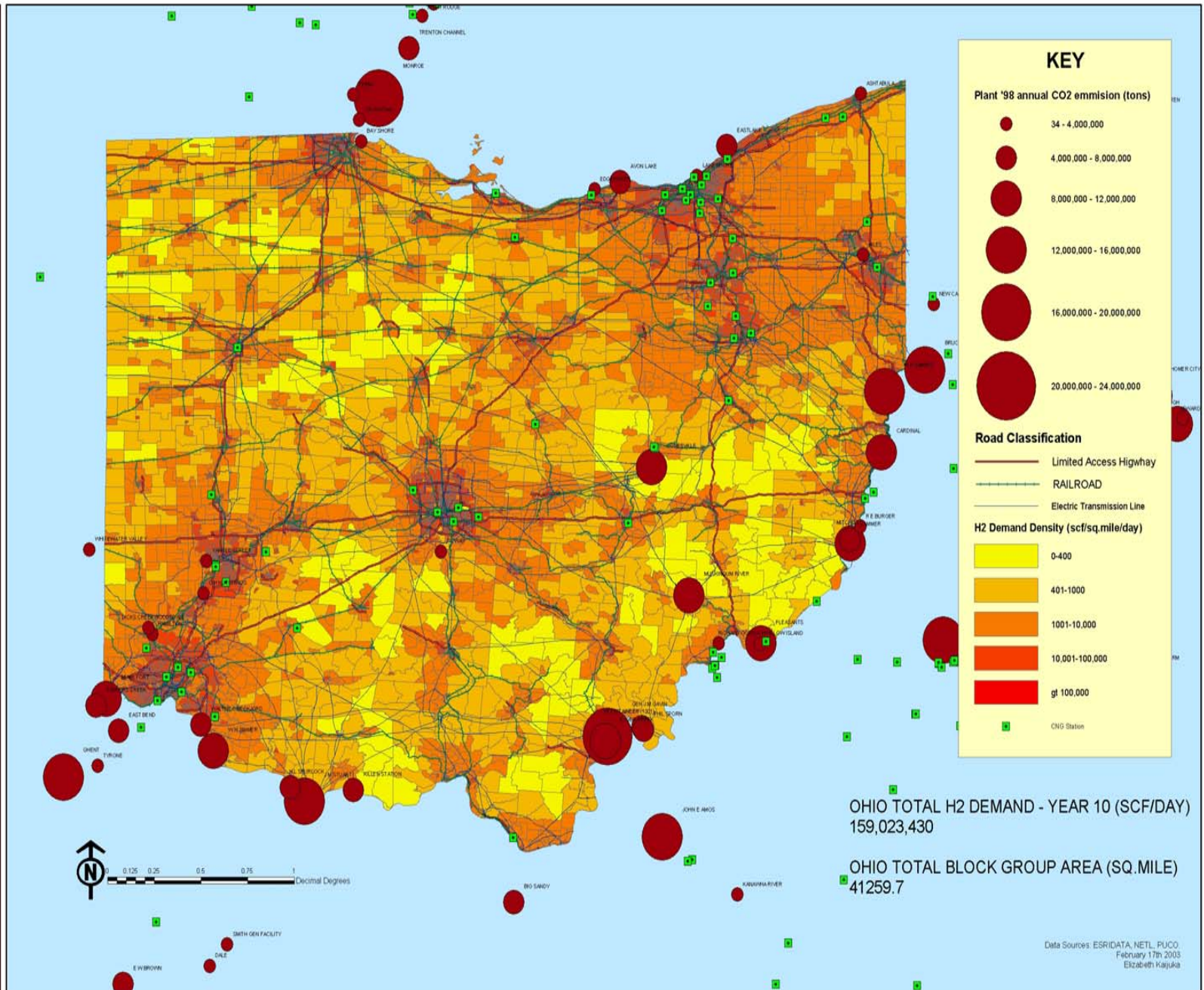

H<sub>2</sub> DEMAND DENSITY (kg/d/km<sup>2</sup>):

YEAR 1:

25% OF NEW Light Duty Vehicles = H<sub>2</sub> FCVs

Blue shows good locations for refueling station



H<sub>2</sub> DEMAND DENSITY (kg/d/km<sup>2</sup>):

YEAR 5: 25% OF NEW LDVs = H<sub>2</sub> fueled

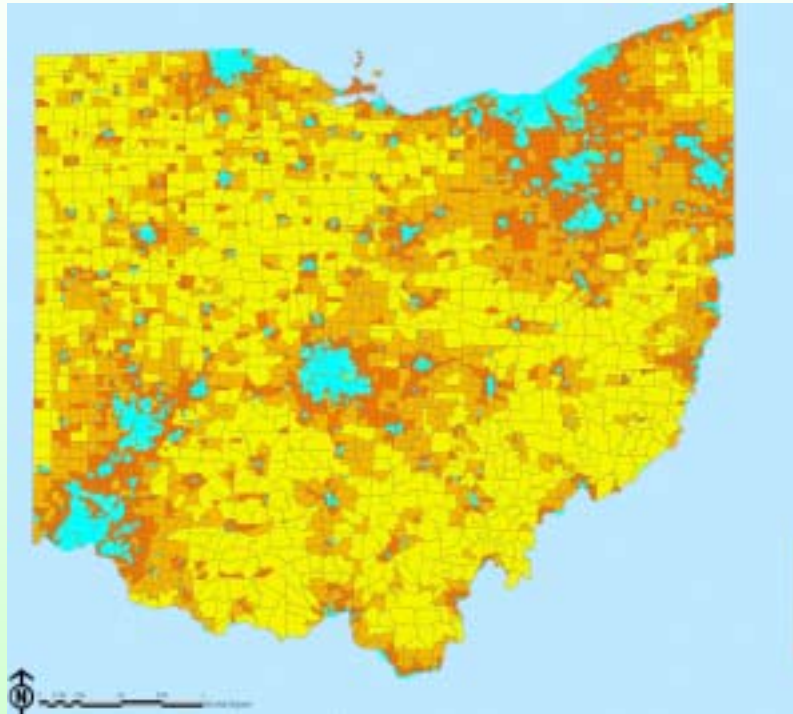

H<sub>2</sub> DEMAND DENSITY (kg/d/km<sup>2</sup>):

YEAR 10: 25% OF NEW LDVs = H<sub>2</sub> fueled

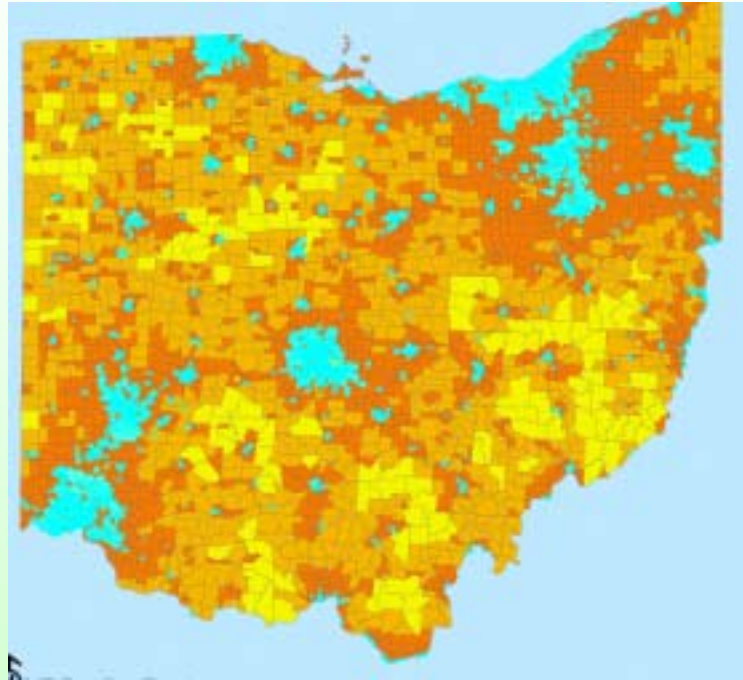

H<sub>2</sub> DEMAND DENSITY (kg/d/km<sup>2</sup>):

YEAR 15: 25% OF NEW LDVs = H<sub>2</sub> fueled

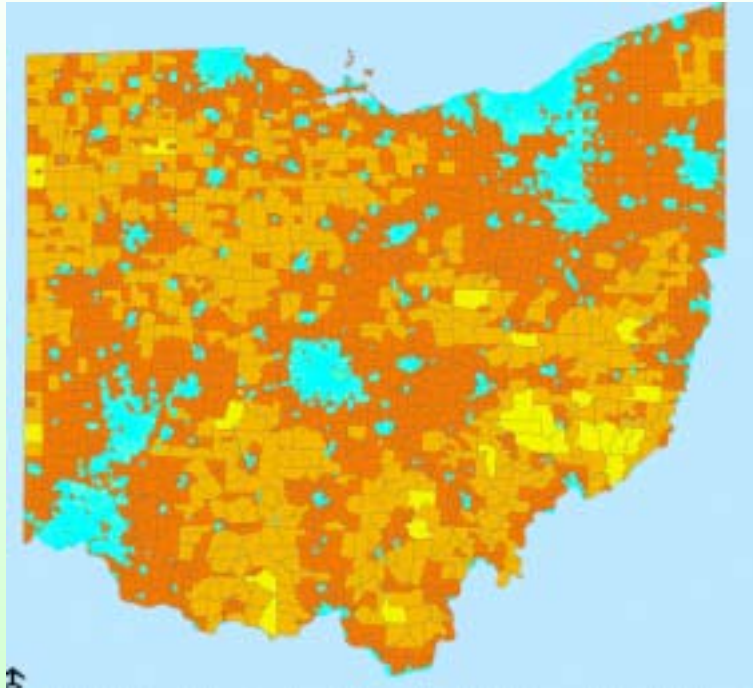

# *What is Required to Enable a H<sub>2</sub> Economy?*

- Safe / effective / low cost CCS
- H<sub>2</sub> safety
- Better H<sub>2</sub> storage?

# *From Multiple Targets and Baselines to The Stabilization Wedge in Three Steps*

Step One: Restrict attention to 50 years (the Goldilocks time frame)

Step Two: Choose just one goal and one baseline

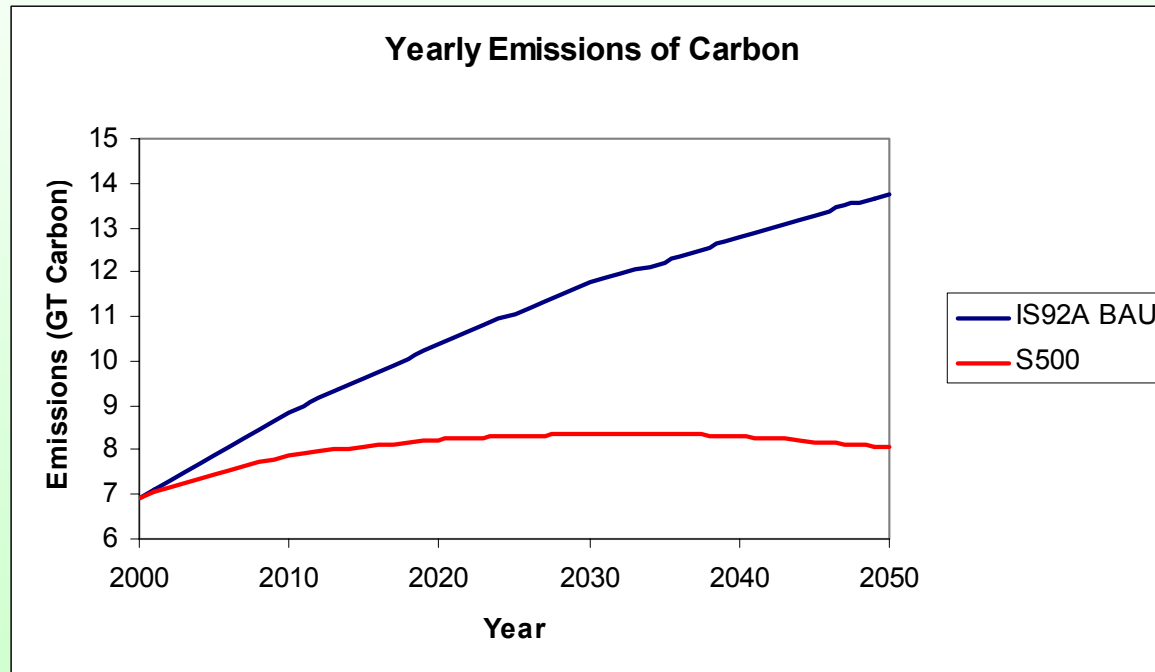

Step Three: Abstracting further, take the goal to be flat emissions and the baseline to be doubling linearly in 50 years.

# The Stabilization Wedge

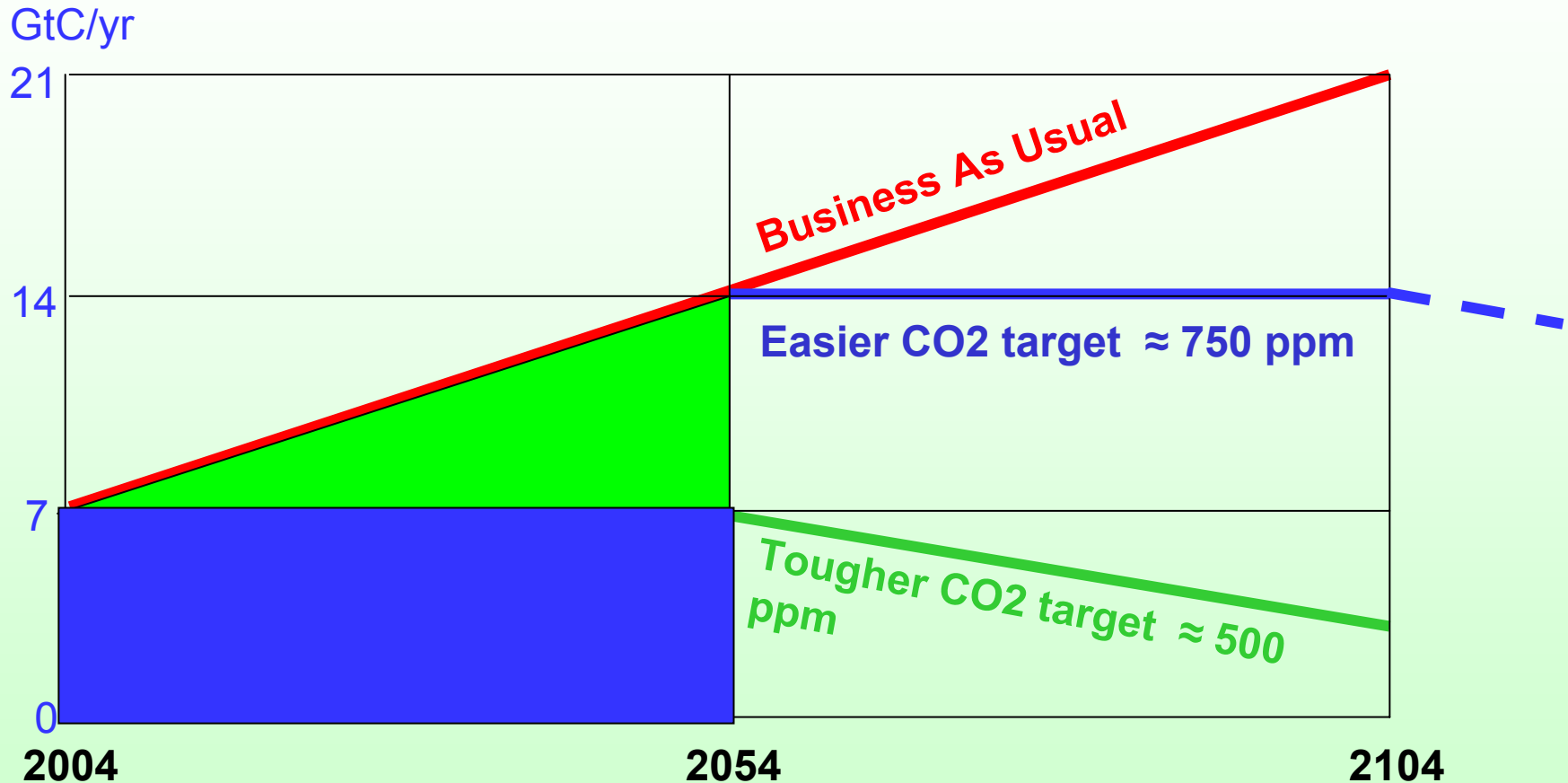

# Seven “Slices” Fills the Wedge

It is irresistible to divide the wedge into seven equal parts. We call these “slices.”

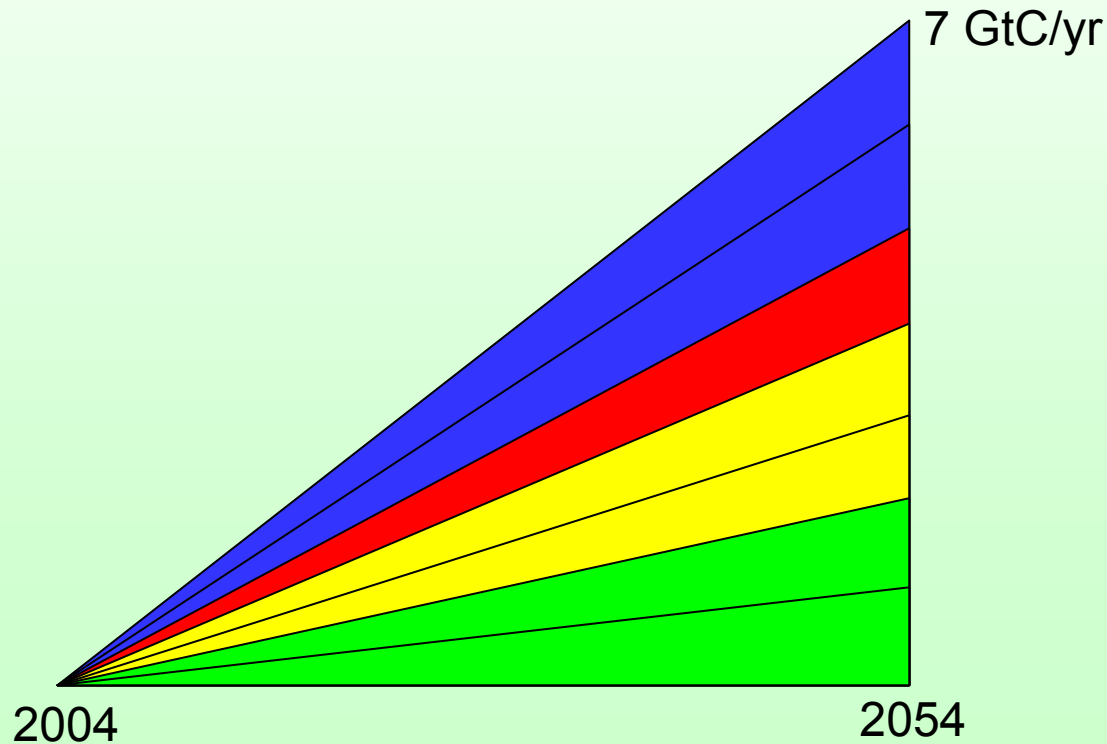

# What is a “slice”?

A “slice” is an activity reducing the rate of carbon build-up in the atmosphere that grows in 50 years from zero to 1.0 Gt(C)/yr.

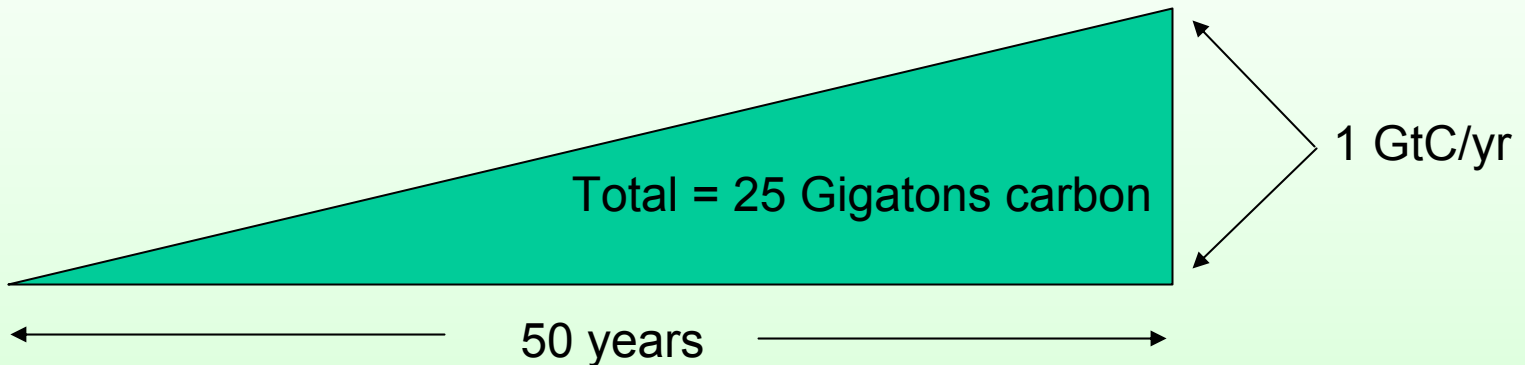

Cumulatively, a slice redirects the flow of 25 Gt(C) in its first 50 years.  
This is 2.5 trillion dollars at \$100/t(C).

A “solution” to the Greenhouse problem should have the potential to provide at least one slice.



# Filling the Wedge

The strategies available to provide the slices to fill the wedge are grouped below. All strategies are based on technologies already in use.

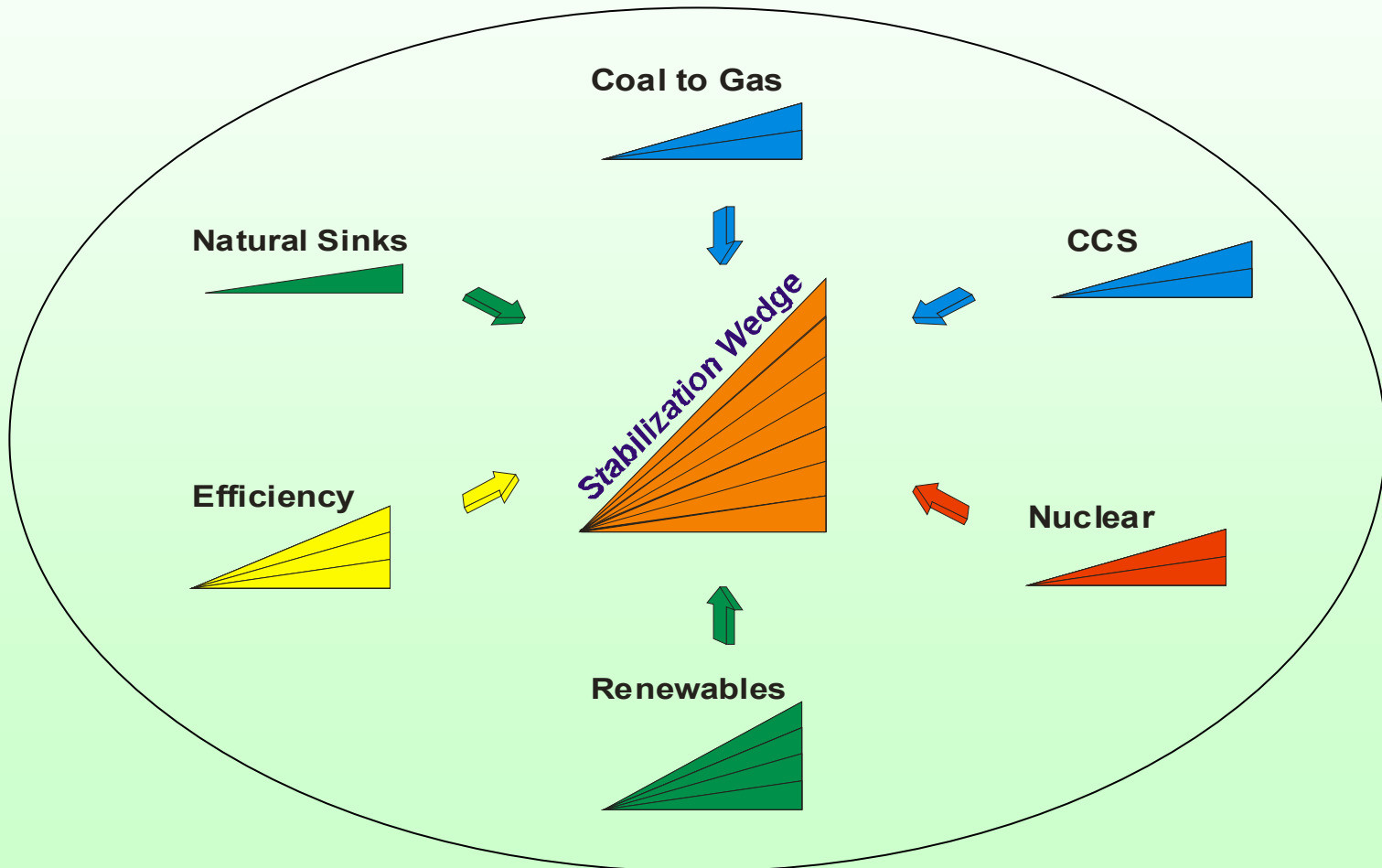







# *Parting Thoughts/Questions*

- Lowering the cost of H<sub>2</sub> from fossil fuels is hard work!
- The cost of H<sub>2</sub> production *per se* may be only a small fraction of the cost of a H<sub>2</sub> economy.
- Thus, how useful is it to try to squeeze production costs via novel technology?
- Other (e.g. system) issues may have greater leverage.
- How soon will H<sub>2</sub> play an important role in carbon mitigation?
- How can we best use our talents to forestall global climate change?