

Separation enhanced reactors for de-carbonisation of fossil fuels

Peter Alderliesten & Daniel Jansen
Energy research Centre of The Netherlands

Palo Alto , 26 April 2004



Content

- Introduction
 - ECN
 - Relevant R&D programmes
 - De-carbonisation of fossil fuels
- Separation enhanced reactors
 - Why
 - Membrane reactors
 - Sorbent reactors
- Conclusions



ECN

Mission

We develop high level knowledge and technologies for a sustainable energy system

Priority areas:

Energy efficiency & conservation

- Solar PV
- Wind
- Biomass
- Clean Fossil fuels & Fuel cell technology



ECN (2)

ECN's core competence and added value

- Materials R&D
- (electro)catalyst R&D
- Process technology
- System analyses

- Large and complex programmes and projects
- Extended experimental facilities
- Networks with universities and stakeholders



Relevant ECN R&D programmes

- Energy Efficiency in Industry

- Separation Technology
 - Inorganic membranes
 - Membrane reactors
 - Membrane processes



- Clean fossil fuels

- H₂ as energy carrier/fuel
 - Production with CO₂ capture
 - End-use for power production in gas turbines and fuel cells

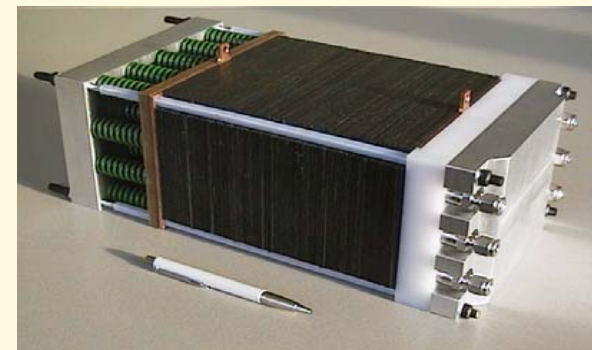

De-carbonisation of fossil fuels

- Natural gas to hydrogen
 - Steam reforming
 - Water gas shift
 - Hydrogen/CO₂ separation

- Coal to hydrogen
 - Gasification
 - Water gas shift
 - Hydrogen/CO₂ separation

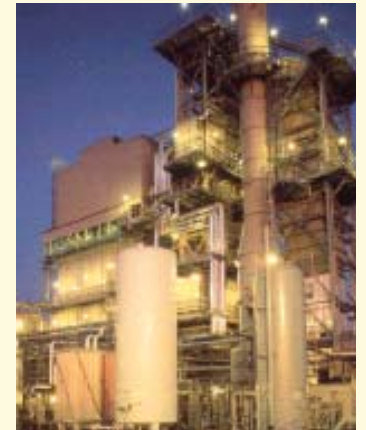

Separation enhanced reactors

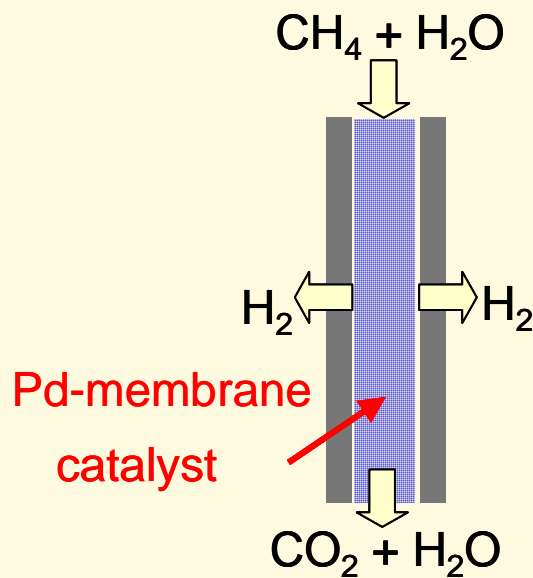
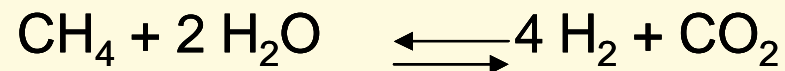
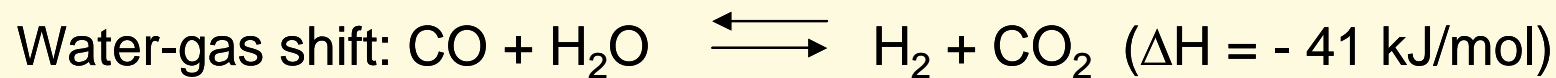
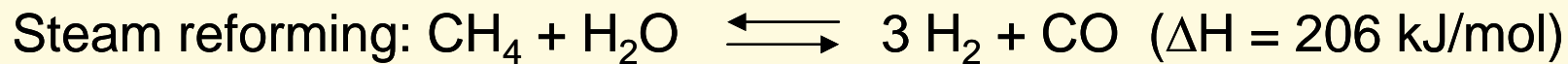

• Membrane reactors

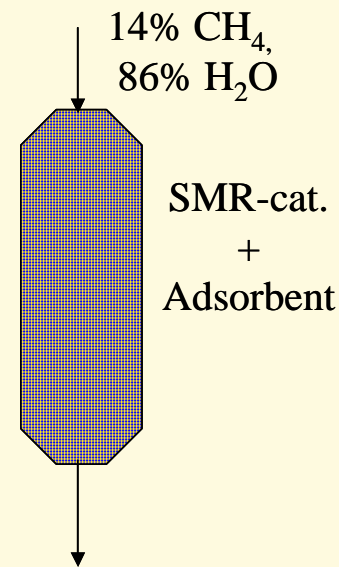

• Sorption enhanced reactors

SER

Why

- Advantages
 - integration of process steps thus
 - lower temperatures
 - high product yield
 - cheaper construction materials
 - compactness
 - energy savings
- Disadvantages
 - not yet proven technology
 - complex unit operation
 - less degree of freedom in design

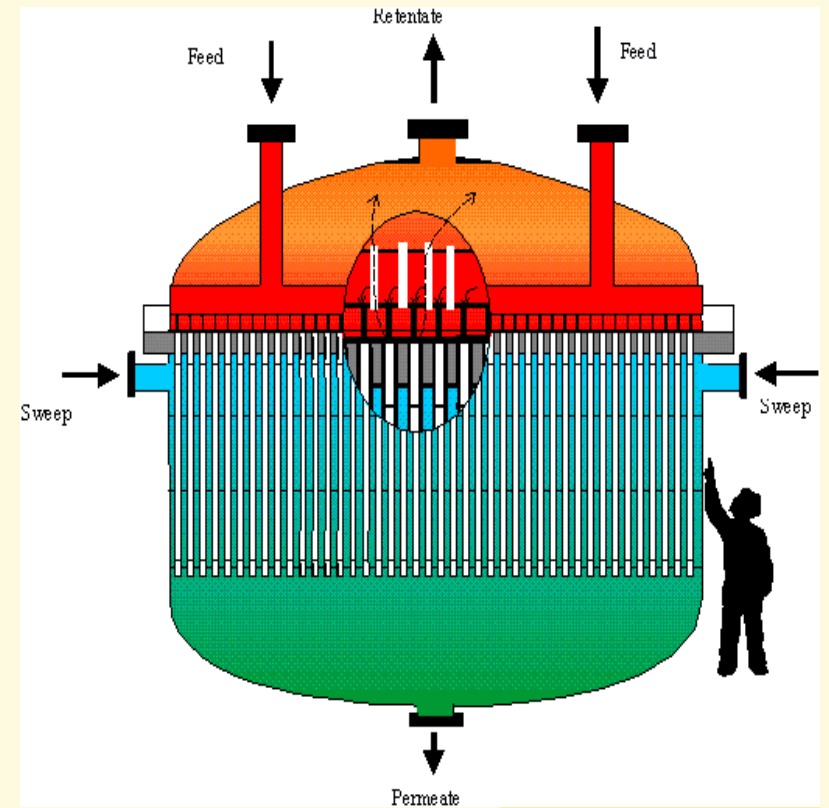

Membrane reactor R&D at ECN

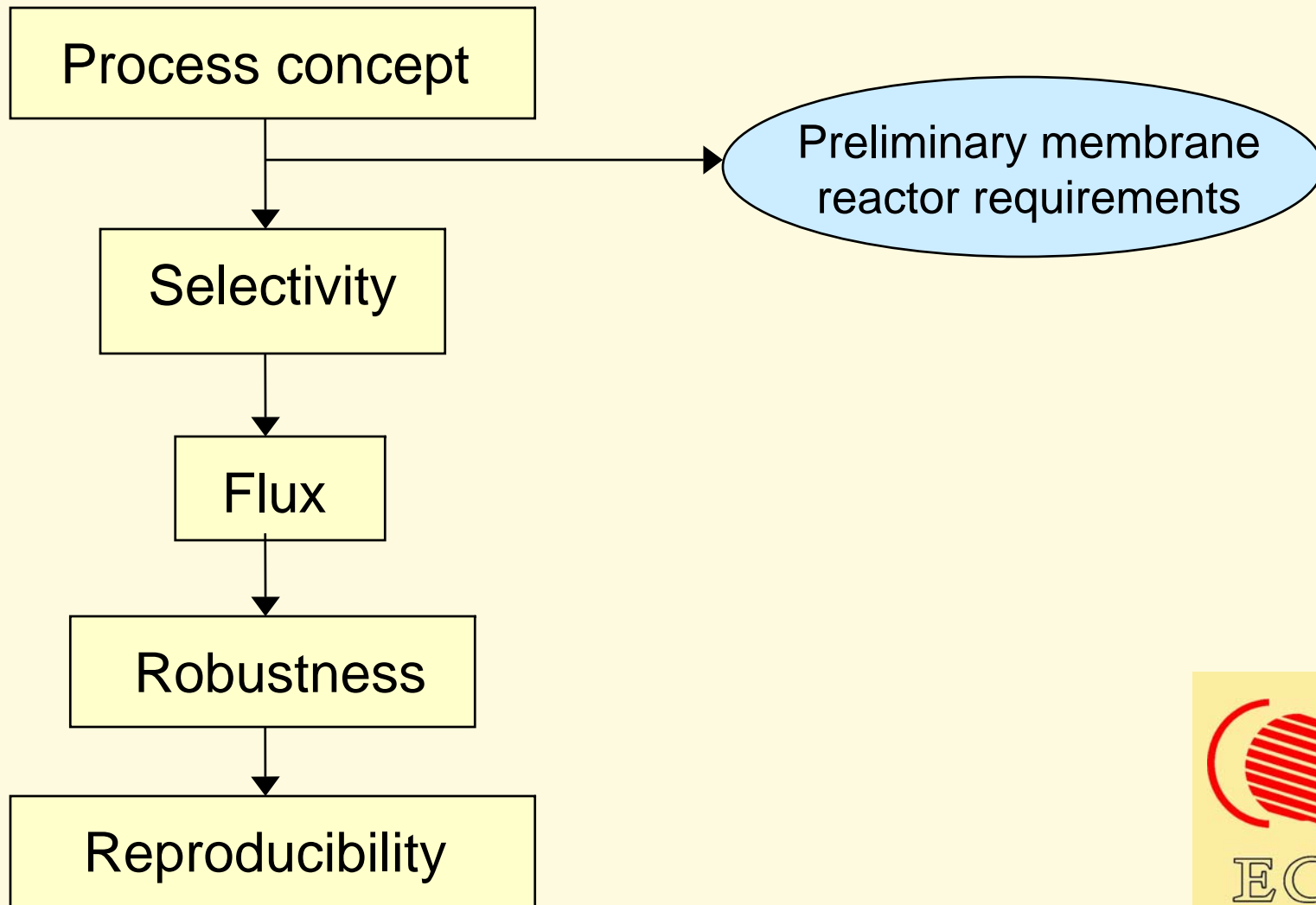

Results

Process concept hydrogen production for ammonia

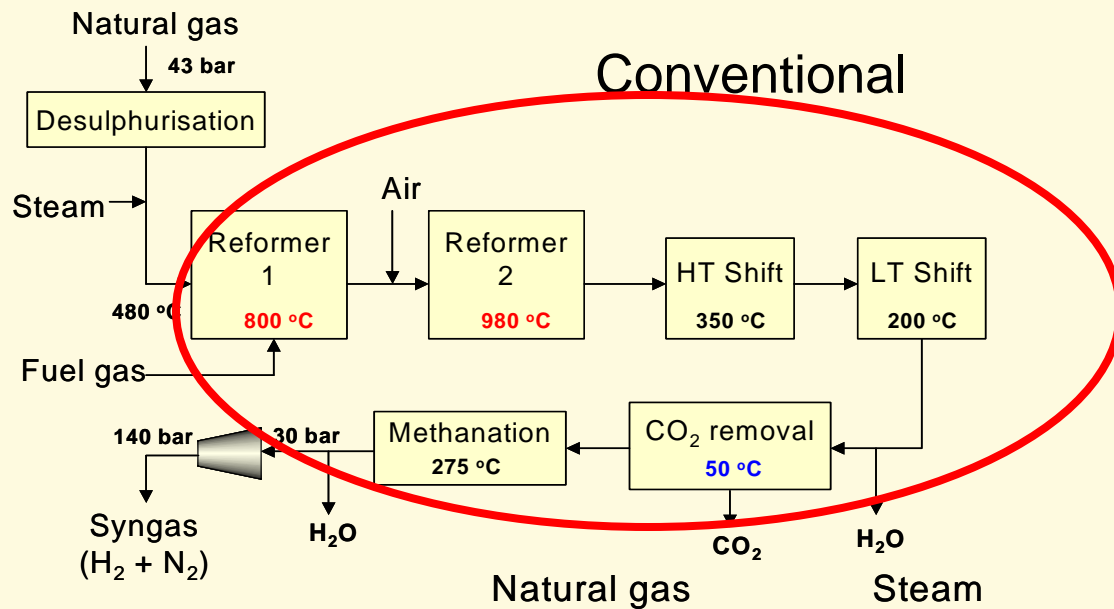

Energy saving: 12%

New scheme including membrane reactor

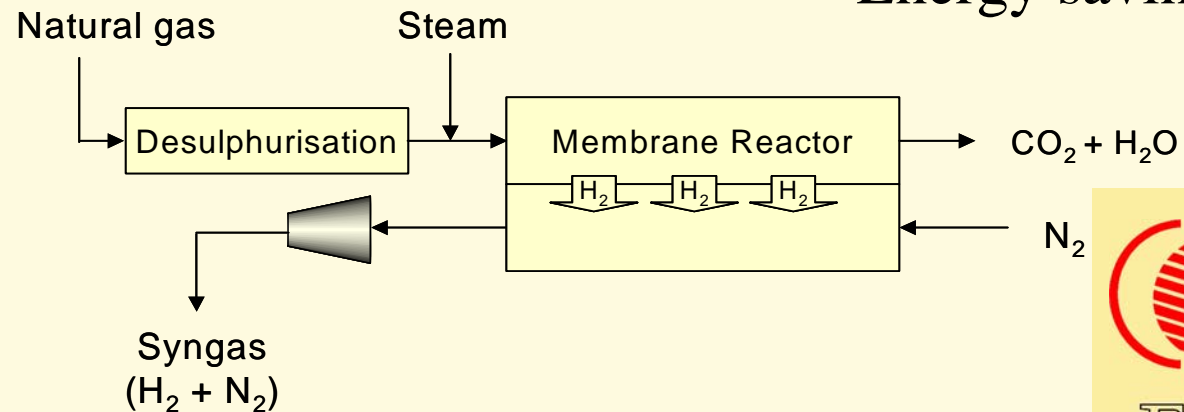

Results

Process concept hydrogen for power generation

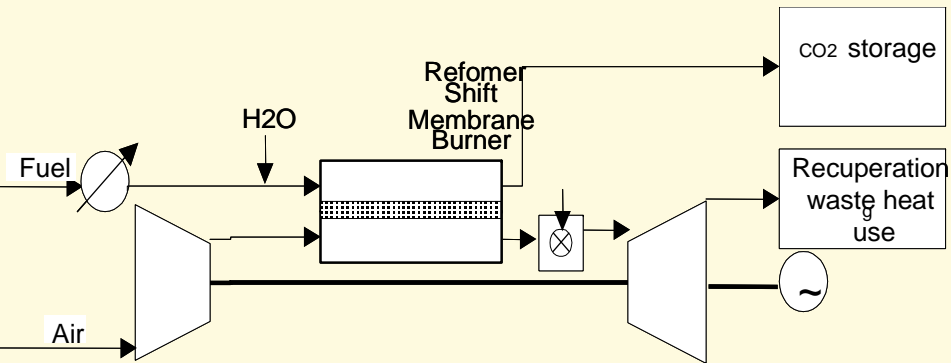
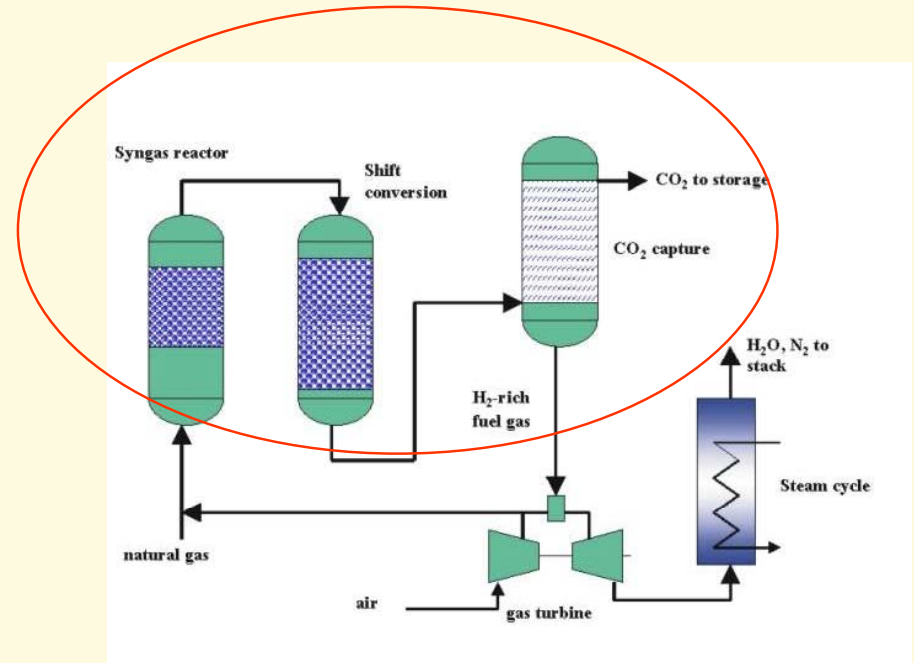
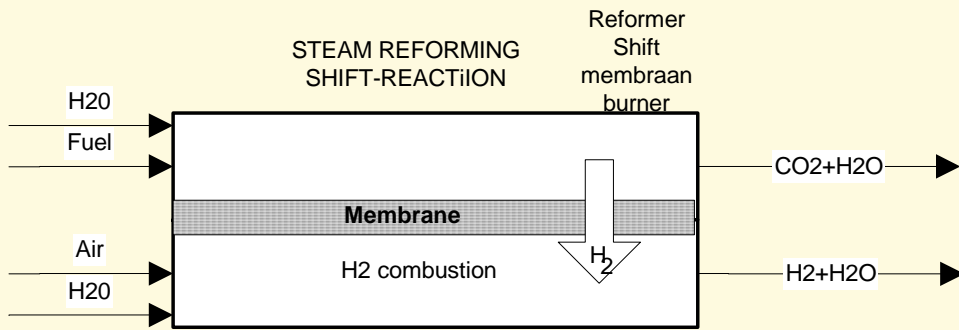

CO₂ capture cost can be reduced with 50%

Results

Preliminary requirements

- High selective, high flux, membrane operating at 300- 500 C
- Hydrogen recovery >98%
- Process membrane flux 50 ~100 kW(H₂-eq.)
- Membrane price ~ 1400 Euro/m²
- Membrane lifetime > 2 years

Approach

- Development of asymmetric, thin layer Pd/alloy membranes
- Membrane/process testing
- Basic unit design



Results

Thin layer Pd alloy membranes

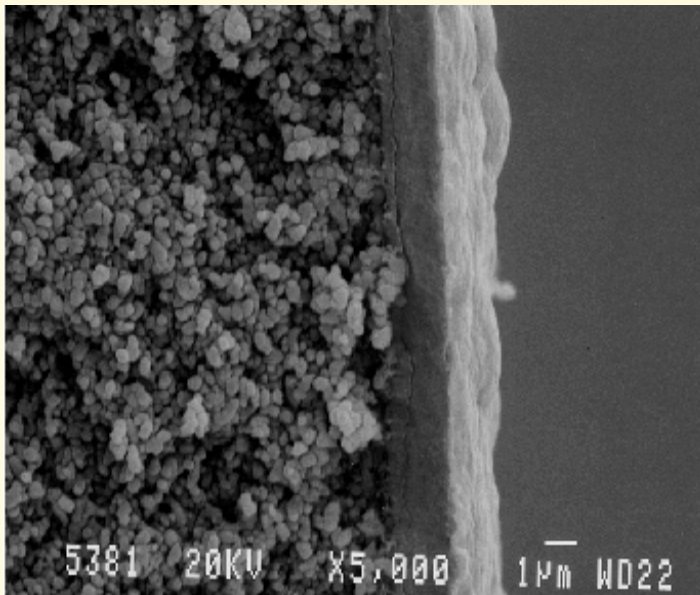

Production procedure:

- Pd precursor variation
- Controlled nucleation
- Sequential electroless plating (growth)
- Annealing/alloying

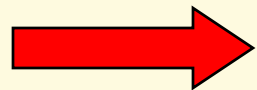

Thin layer defect free membrane ~ 3 micron



Results

Thin layer Pd alloy membranes (2)



Metal substrate



Ceramic substrate

Results

Performance measurements ECN Pd/Ag membranes

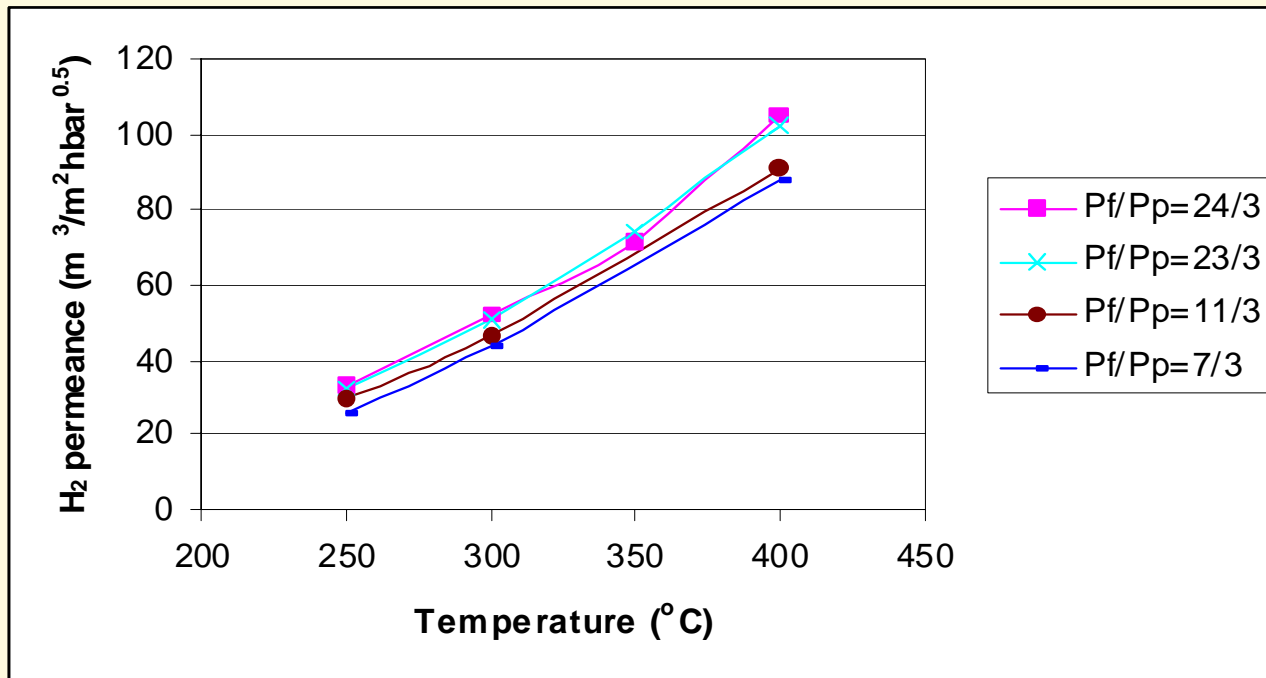

Pf= feed pressure in bara

Pp= permeate pressure in bara

SMR-conditions

- Stable operation for 3 months
- Selectivity H₂/CO₂ ~ 4000
- Permeance 50 ~ 100 kW H₂-eq
- T-Cycling in N₂ o.k!



Results

Ageing !

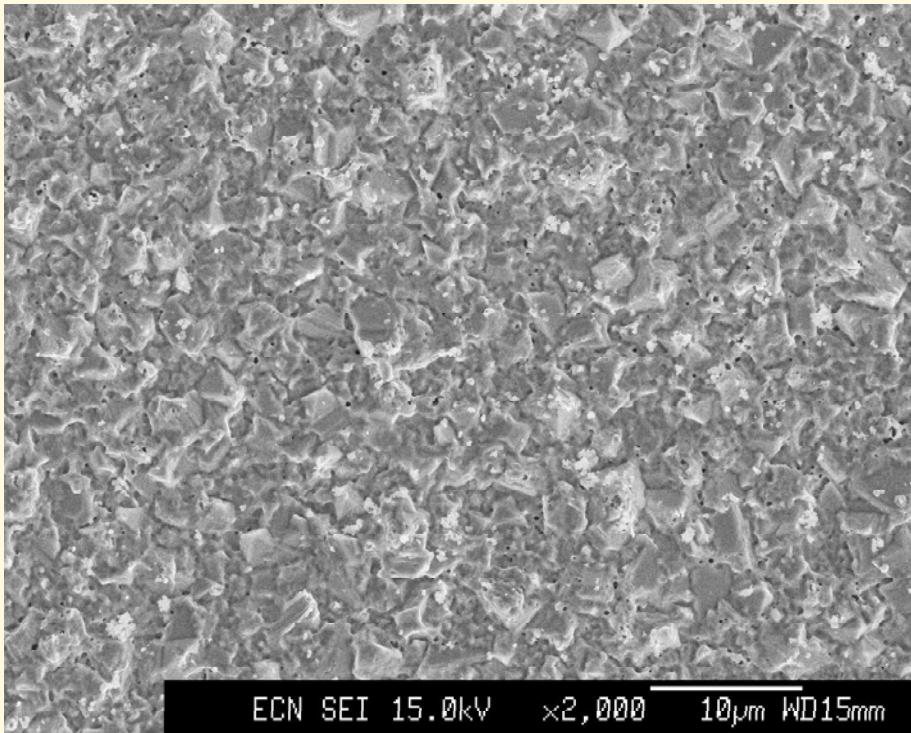

Before use

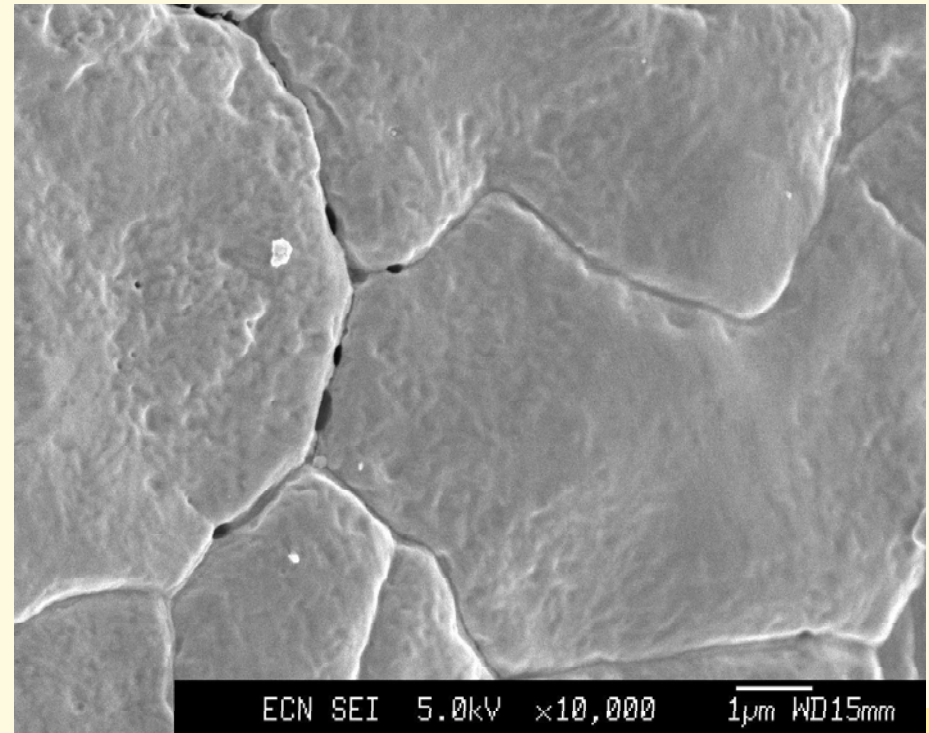

Ageing in hydrogen

Results

Equipment development: Module design and sealing

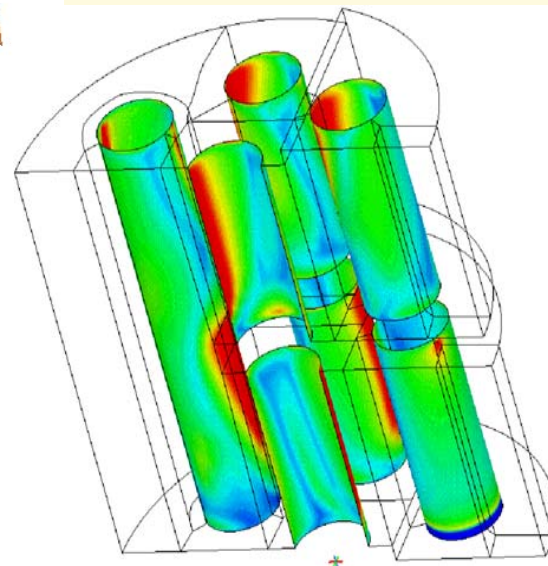
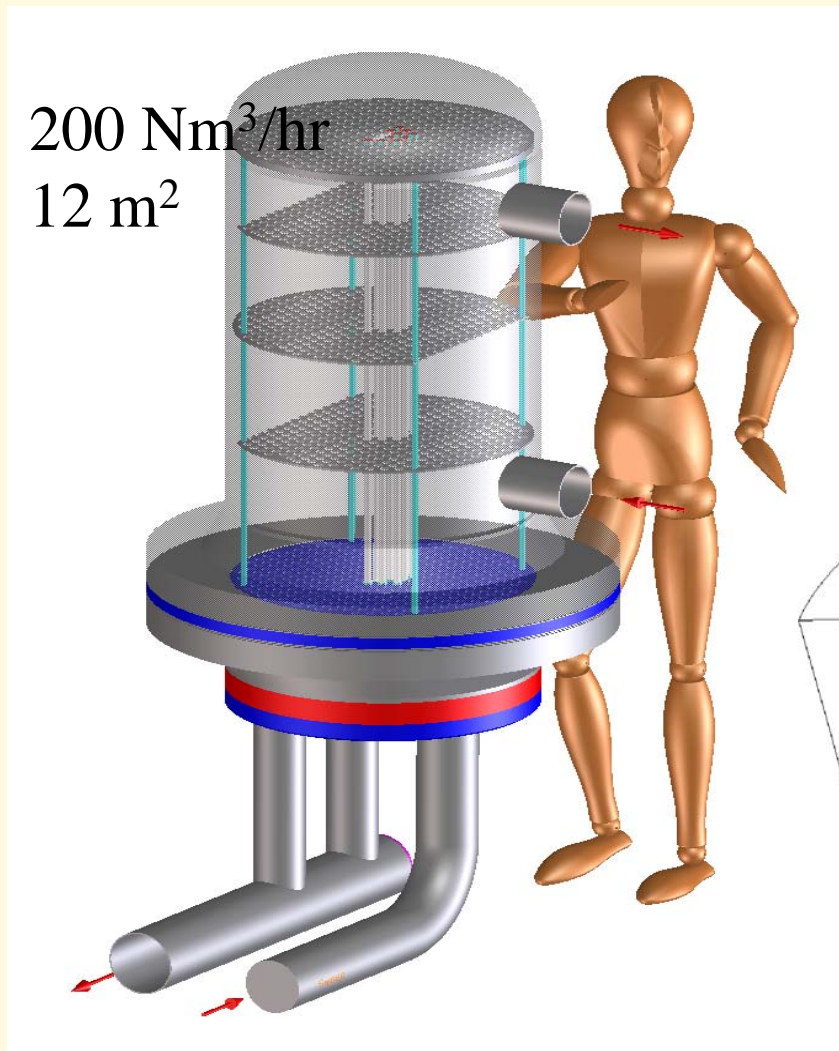

- 600°C, 150 bar
- Reducing atmosphere

Conclusions and future work MR

- Conclusions
 - Pd/alloy membrane promising technology
 - Process concepts look feasible
 - Membranes are dynamic
- R&D issues near future
 - Performance: understanding flux/selectivity in operation
 - Stability: fouling, poisoning, material microstructure
 - Reproducibility: upscaling aspects
 - Detailed module design, construction, MR experiments



Sorption enhanced reforming process basic aspects

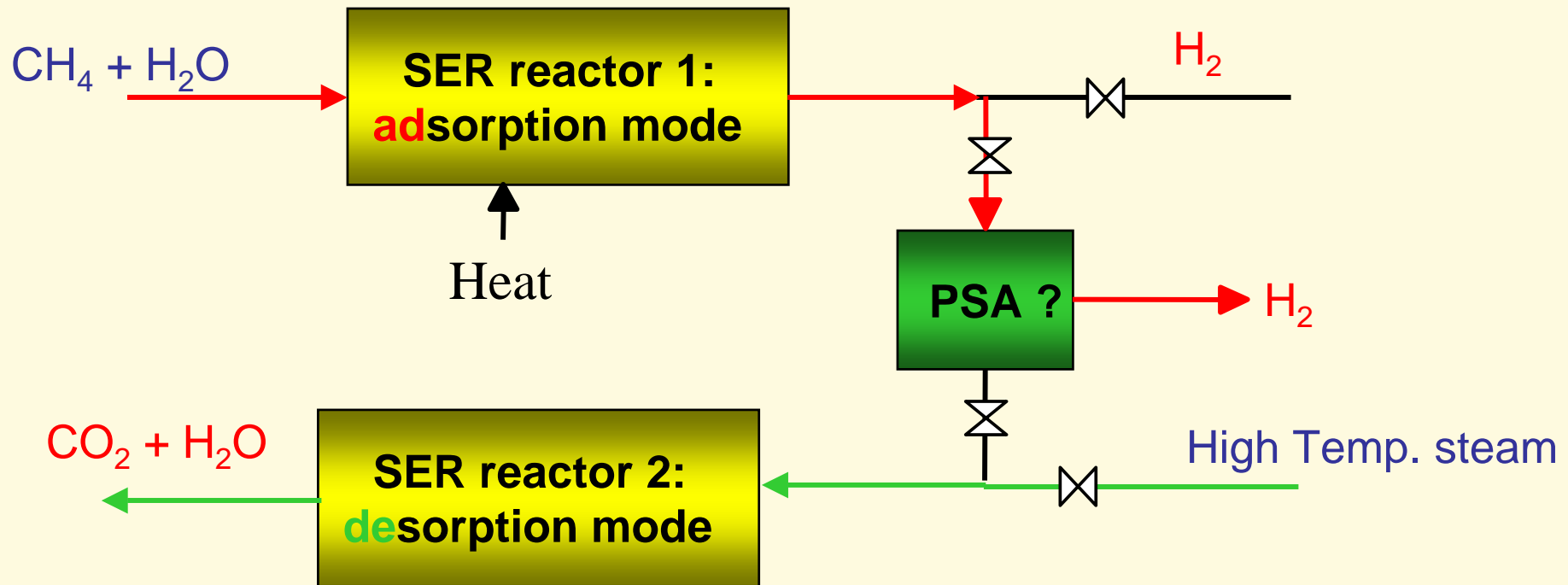

- Cyclic batch operation
- Steam-reforming/water-gas shift reaction
- Pressure swing adsorption optional
- Hydrotalcites as promising CO_2 -adsorbents

Results SERP

Base case system analysis

- Three main challenges:
 - High conversion of CH_4 (>98%) needed
 - Reduction of CO_2 stripping steam
< 3 moles steam / mole CO_2
 - 85% CO_2 capture

} High efficiency

- Approach
 - Improve/new catalyst and adsorbent
 - Process optimization (cycle times)
 - Innovative system configurations



Results SERP

CH₄ conversion

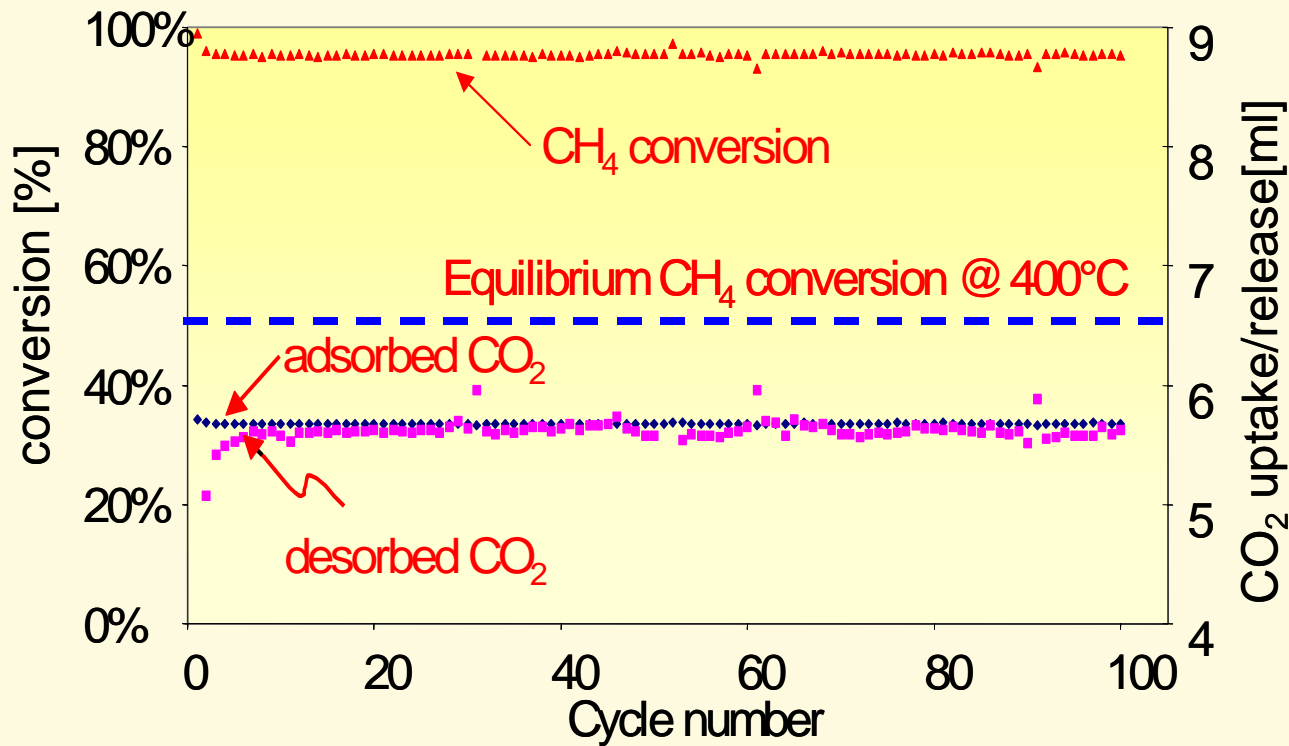

ECN catalyst/sorbent

- 98% conversion at 400 °C until breakthrough of CO₂
- 85% CO₂ capture
- Steam/CO₂ ratio > 10
- Ad=des



Results SERP

Lowering steam demand

- Modification of adsorbents:
 - Promising new hydrotalcites and promoters found
 - Alkali metal carbonates
 - Further development on going in co-operation with Utrecht University
- Process optimization:
 - Short cycle times
 - Dynamic modeling of adsorption/desorption process



Results SERP

System Configurations

- System and pinch analysis,
- Identification of innovative process schemes with gas turbines and fuel cells

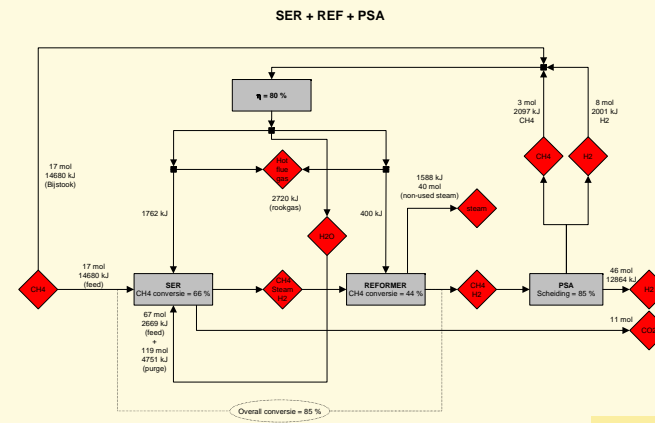
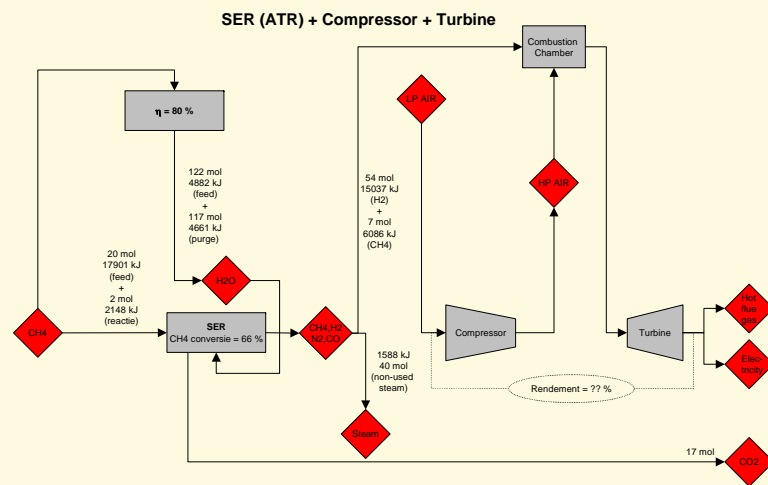

Conclusions and future work SERP

- Conclusions
 - Methane conversion $> 98\%$ feasible at $T=400\text{ C}$
 - No breakthrough of CO_2
 - CO_2 removal efficiency of 85% feasible
 - No hysteresis
- R&D issues
 - Steam/ CO_2 ratio < 3 (shallow ad- desorption mode)
 - ATR – SERP (GT application)
 - Preparation methode cat/sorbent combi
 - Sorbent lifetime



Final

- Separation enhanced reactors
 - MR and SERP in progress
 - Next two years decisive
- Acknowledgements
 - Colleagues and co-workers
 - Ruud v.d. Brink, Paul Pex, Yvonne van Delft, Lucy Correia, Jan Wilco Dijkstra and others
 - GSEP for the invitation
 - Sponsors
 - Dutch ministry of Economic Affairs, EU, e.o.

